

BMD PLUG GAUGES

Technical Guide

Version 4.1

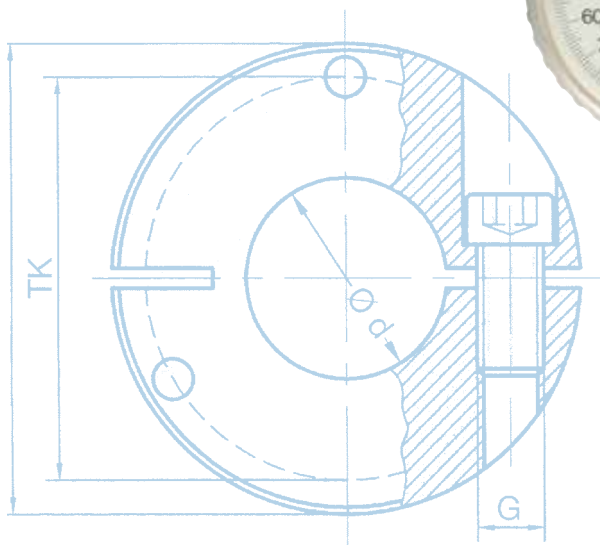

Content

Page

- 3** DIATEST - Expertise for precision and safety
- 4** Technical description
- 9** Basic plug gauge types
- 10** Basic type - Standard
- 11** Basic type for through bores
- 12** Basic type for blind bores
- 13** Basic types with compressed air supply
- 14** Plug gauges for automatic gauging
- 15** Special-purpose plug gauges
- 21** PA for measuring parallel wall gaps
- 22** Multiplane plug gauges
- 24** Indicator holders
- 27** Indicator holders with adjustable spring pressure
- 29** Electrical probe holders
- 30** Special gauge holders
- 33** Holders for Analodig indicators
- 34** Adapters
- 36** Right-angle attachments
- 37** Depth extensions
- 40** Depth stops
- 42** Small measurement fixtures
- 46** Floating holders
- 50** Spare parts
- 51** General and technical abbreviations



DIATEST manufactures high-precision bore gauging instruments and metrological solutions

High-volume engineering does not work without precision, a global production depends on local experts.

To achieve highest possible safety in production precision is necessary starting from design to final product as well as a qualified and trained local DIATEST partner speaking the national language and knowing the products.

Our clients are manufacturers all over the world demanding a high standard of accuracy and quality, for example the aviation and aerospace industry, the automobile and hydraulics industry, medical industry as well as general engineering.

Your advantage as user: regardless of industrialized country of production you can always feel safe due to DIATEST quality. Your local DIATEST partner takes care of you. Our partners not only know their country, culture, language and market, but also have experiences and know-how of DIATEST and quality control.

The name DIATEST guarantees worldwide quality, expertise and safety. Measuring instruments with an accuracy of up to 0.0002 mm / 0.000008 inch ensure an absolutely accurate result. DIATEST is DIN ISO 9001 certificated.

Future-orientated manufacturing technology (*Industrie 4.0, VDA volume 5, etc...*), well-trained precision engineering technicians and engineering knowledge guarantee highest quality standards. Whether standard- or customer specific solutions, DIATEST measuring instruments will be adequate for future tasks.

This is the company's philosophy, carried out by an experienced staff: Highest quality at a fair cost effectiveness, combined with expert advice and absolute faithfulness to deadlines in dealing with all DIATEST customers. For us this is a service taken for granted which our DIATEST partners worldwide appreciate. This is what partnership means to us.

DIATEST – Safety through quality, precision and competence in more than 40 countries of the world



Technical description

Plug gauges (BMD) are self-indicating, self-centering, high precision measurement instruments. These easy-to-use gauges are suitable for both static and dynamic measurements. They can be used for manual detection of dimensional deviations and shape defects in bores in serial measurement at the machine but may also be installed in measuring equipment and automated systems.

A broad range of applications, ease of handling, superior precision and rugged construction are combined in a highly cost-effective system.

A wide selection of basic types in the standard programme, supplemented by useful accessories, ensures that nearly all bores encountered in actual practice can be measured precisely.

The range of display instruments includes mechanical indicators, digital displays and sensors connected to analytical equipment. Peripheral equipment provides for static data analysis, dimension-based tool control and many other useful options.

Special models

The BMD Technical Guide is intended to assist you in selecting the most suitable measurement equipment. For special measurement problems we need a detailed description of the measurement task as well as a drawing or sample in order to prepare an offer. An optimum offer depends on precise, complete information.

Please note: Deviations regarding technical aspects of specially designed BMD gauges as opposed to standard gauges are possible!

Special markings (SO-B)

Special markings data matrix code (SO-B-DMC) (extra charge)

We can provide special markings, such as customer-specific ID numbers, tolerances, etc. Please keep in mind that the possibilities for adding special markings to small plug gauges are limited. The surcharge for SO-B is calculated for each commenced 10 characters (see price list).

Design and material characteristics:

Probe: spring steel, approx. 61 HRC

Needles: carbide, approx. 1650 HV

Guide cylinder: gauge steel or stainless steel.

Special cylinder designs:
OCR = steel cylinders, hardened and black finished

Please note: OCR plug gauges are not suitable for rough measurement conditions.

ZHML = cylinder with carbide bars, 14

ZKUL = cylinder with plastic bars, 17

Technical data

All dimensions are quoted in mm unless otherwise specified. We reserve the right to make technical modifications in order to improve performance. Minor deviations which do not impact significantly on measurement equipment performance may occur.

Information regarding technological advances and the most recent version of our documentation is also available on the Internet at www.diatest.com

Zero setting

Zero setting should be performed with the aid of a setting ring that corresponds precisely to the minimum bore size. This ensures that the risk of radial and axial errors is largely eliminated during

the calibration process.

The most suitable setting rings are those which comply with the specifications of DIN 2250-C. Setting rings with larger dimensions or for minimum, medium and maximum dimensions are generally not required.

Function

The guide cylinder (4) centers the probe gauging contacts (6) fixed to the split ball probe (5) axially and radially in the bore.

The lapped cone of the needle (3) translates the distance travelled by the gauge contacts 1:1 to the indicator (1) clamped in the holder (2).

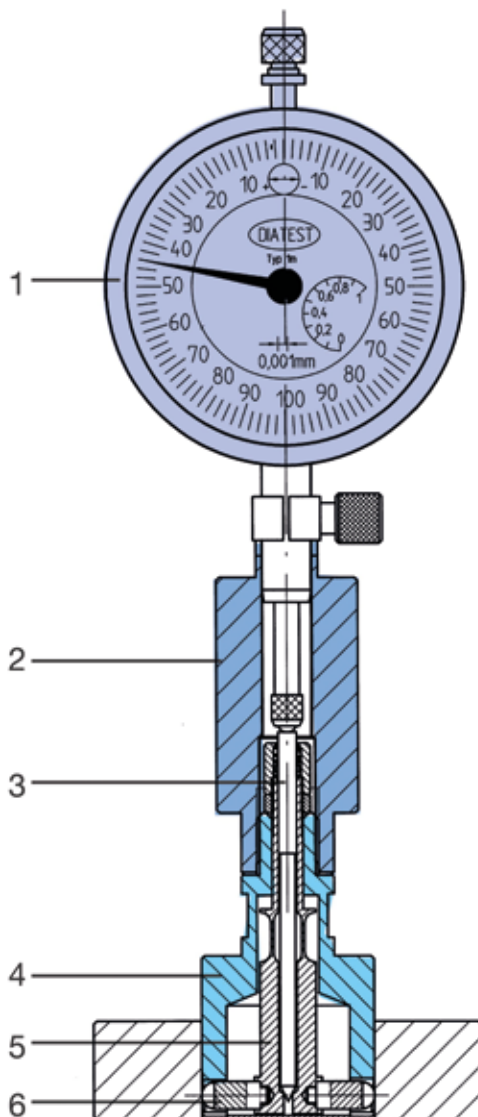

TA-KW



SO-ZL

Production times

Production times are quoted ex factory, as shown in the table below.

Service life

Service life depends upon such conditions as work piece surface quality (roughness, coating), material, length of measured bore, dirt accumulation, gauging pressure etc. Up to a few million measurements are possible under optimum conditions.

Repair Service

Diatest offers a fast and cost-effective repair service for standard BMD.

Service 1: Exchange of gauging unit and functional testing. Approx. 10 working days, ex works.

Service 2: Exchange of gauging unit, fully re-chromed cylinder and functional testing. Approx. 15 working days, ex works.

A cost estimate for special BMD plugs will be provided (on request).

Maintenance

No special maintenance is required. If cleaning is needed, remove the needle and clean the plug gauge and the needle carefully with compressed air and a cleaning solution.

Please note: The needle taper should be greased prior to installation (e.g. Vaseline). When installing needles for Series 6 and 10, please ensure that springs are remounted (no springs in Series 4).



Gauging accuracy

Maximum allowed deviations with new plug gauges:

Repeatability

2-point design

$fw \leq 0.001$ mm

3-point design

$fw \leq 0.002$ mm

Measuring range transmission

error (Linearity)

2-point models

$fe = 1\%$ of gauging distance

min. 0.001

3-point models

$fe = 3\%$ of gauging distance

min. 0.002

FB design

$fe = 2\%$ of gauging distance

min. 0.001

Measurement range extension (MB-SO) and special designs may lead to a reduced measuring accuracy.

Axial and radial centering errors

The plug gauge guide cylinder positions the gauging contacts in the bore and ensures high repetition accuracy. Short guide paths and/or excessive clearance between the bore and the guide cylinder result in lower repeat-

ability due to tipping and lateral shifting.

Nominal dimensions and standard measurement ranges

Plug gauge order dimension (nominal dimension) = minimum bore dimension

Example:

$\varnothing 35 D7 = \varnothing 35 +0.08/+0.105$

BMD nom. dimension = 35.08

$\varnothing 35 H7 = \varnothing 35 +0/+0.025$

BMD nom. dimension = 35.0

Measuring range extension (MB-SO) (extra charge)

The standard measuring range can be extended for applications requiring measurement of larger bore tolerances. Please note: Some plug gauges with MB-SO have smaller contact point radii. This poses the danger of axial and radial errors. Please enquire before using diamond measurement contacts.

A measuring range extension of e.g. MB-SO+0.4 indicates that the entire measurement range of the plug gauge is 0.4 mm, based on the nominal plug gauge dimension.

Measurements taken in horizontal direction may lead to smaller measuring ranges.

Standard production times

Plug gauge type	working days
S, D, PK, OR, 2R, S-FB up to nom. dim. 100 mm	10
S, D, PK, OR, 2R, S-FB above nom. dim. 100 mm	15
FB, 3P, L, PK-2Z, MZ, AT0	15
SO-TA, UM, PA, SO-W10, T-BMD	25
ZHML	30

Saturdays, Sundays, public holidays and company holidays are not counted as production days and will extend delivery times accordingly.

Express production times (extra charge)

Plug gauge type	working days
S, D, PK, OR, 2R, S-FB up to nom. dim. 100 mm	5-8
S, D, PK, OR, 2R, S-FB above nom. dim. 100 mm	8-10
FB, 3P, L, PK-2Z, MZ, AT0	8-10
SO-TA, UM, PA, SO-W10, T-BMD, ZHML	15

Delivery times for all other plug gauges, including multiplane gauges, etc., will be quoted on request.

Measuring range, based on nominal BMD dimension

BMD series	Application range	Measuring range
4	$\varnothing 2.98 - 9.0$	+ 0.1 mm
6	$\varnothing 7.0 - 20.0$	+ 0.15 mm
10	$\varnothing 15.0 - 270.0$	+ 0.2 mm
FB6	$\varnothing 7.0 - 16.0$	+ 0.15 mm
FB10	$\varnothing 15.0 - 150.0$	+ 0.15 mm
3P (Series 6)	$\varnothing 8.0 - 20.0$	+ 0.15 mm
3P (Series 10)	$\varnothing 15.0 - 100.0$	+ 0.2 mm
T-BMD	$\varnothing 2.25$ (PA 1.0) - 2.98	+ 0.15 mm

Measuring range extension (MB-SO)

BMD series	max. meas. range (order suffix)
Series 4 $\varnothing 2.98 - 4.0$	max. MB-SO + 0.15
Series 4 $\varnothing > 4.0$	max. MB-SO + 0.2
Series 6	max. MB-SO + 0.4
Series 10 to $\varnothing 120$ mm	max. MB-SO + 0.8
Series 10 $\varnothing > 120$ to 180 mm	max. MB-SO + 0.6
Series 10 $\varnothing > 180$ to 220 mm	max. MB-SO + 0.4
Series 10 $\varnothing > 220$ to 270 mm	max. MB-SO + 0.3
Series FB10 + FB6	max. MB-SO + 0.3
BMD-3P (Serie 6)	max. MB-SO + 0.3
BMD-Series 10 3P	max. MB-SO + 0.4

For option MB-SO we recommend option PG in addition (☐ 8).



Measuring range limitation (MB-B)

For plugs series 6, 10 and FB the standard measuring range can be reduced, if requested.

Order suffix: MB-B and max. desired measuring range.

Sample order for max. measuring range of +0.1 mm instead of 0.2 mm:

BMD-S10-CR-35.0-MB-B+0.1

Washers can also be used to reduce the measurement range. DIATEST offers a line of washers for this purpose:

BMD Series 6 US-6

BMD Series 10 US-10

Indicators, measuring pressure

Plug gauges can be used with nearly all mechanical and electronic indicator units with Ø 8 and 3/8" stem. Measuring pressure has a significant influence on the service life and accuracy of BMD.

Recommended measuring pressures for standard measurement ranges:

BMD Series 4 approx. 0.3 – 0.4 N

BMD Series 6 approx. 0.6 – 1.0 N

BMD Series 10 approx. 0.8 – 1.6 N

Please note:

It may be necessary to increase measuring pressure when using options MB-SO and PG.

Measuring pressure reduction

Only low gauging pressure is needed when using Series 4 BMD, to measure thin-walled objects or to reduce wear on measuring contacts. It is often impossible to obtain a suitable reading. Special indicator holders or adapters can be used to reduce the measuring pressure of the indicator.

In addition, option PG provides for the possibility of lifting the gauging contacts from the bore surface.

Type PG	8
Holder MH6-73-R	24
Holder MH10-150-PG	32
Holder MH10-150-R	25
Holder MH10-150-F	30
Adapter A4-10-F	34
Adapter A6-6-F	35
MH4-67-F	28
MH6-65-F	28

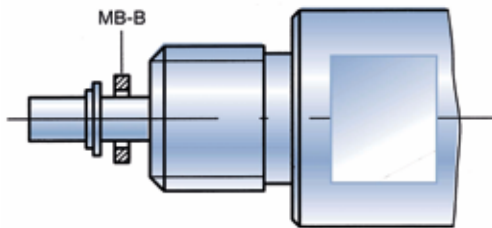

Contact points

Large contact point radii (see table MHM) are important to ensure long service life and are required when gauging bores with rough surfaces. Our BMD gauging contacts meet these requirements.

The selection of gauging contact material depends on the composition of the workpiece and the conditions affecting wear. BMD gauging contacts are available in several different materials.. If you are not sure

which material is best suited for your workpiece please get in touch with us.

Carbide contact points (MHM)
Plug gauges are fitted with carbide contact points (standard, no extra charge).

Carbide: approx. 1850 HV
Carbide should not be used for workpieces composed of non-ferrous metal, aluminium or their alloys.

Hard chrome contact points (MCR)

Hard chrome contacts are suitable for use with non-ferrous metals, aluminium and their alloys.

These contact points are made of carbide steel coated with a hard chrome layer. The hard chrome layer is approx. 0.03 mm thick. Option MCR is not suited for applications involving heavy wear conditions or very soft workpiece materials. In these cases, it is advisable to opt for diamond gauging contacts (MDI).

Contact point radii (see Table MHM)
Hardness: approx. 1000 HV
Order suffix: MCR
Available for nominal diameters of 3,95 and above.
Example:
BMD-S10-CR-35.0-MCR

Ceramic contact points (MKE) (extra charge)

Like option MCR, ceramic contact points are suited for use with non-ferrous metals and aluminium.

When working with very soft aluminium materials, the ceramic material may discolour. This has no impact on performance or measuring accuracy, however. Hardness: Knoop 100g
18000 Grain size: 0.5 µm

Contact point radii (see table MHM)
Not available for series 4 and BMD-FB
Order suffix: MKE
Example:
BMD-S10-CR-35.0-MKE

Contact points carbide (MHM)

BMD series	Diameter range	Gauging radius
Series 4	2.98 - 9.0	R = 0.5
Series 6	7.0 - 20.0	R = 2.0
Series 10	15.0 - 25.0	R = 2.5
	> 25.0 - 31.0	R = 4.5
	> 31.0 - 35.0	R = 6.5
	> 35.0 - 41.0	R = 8.5
	> 41.0 - 47.0	R = 10.5
	> 47.0 - 56.0	R = 13.0
	> 56.0 - 66.0	R = 16.0
	> 66.0 - 120.0	R = 20.0
	> 120.0 - 150.0	R = 25.0
	> 150.0 - 270.0	R = 30.0
Option MB-SO+0.4 to 0.5		R = 4.5
Option MB-SO+0.5 and above		R = 2.5
BMD-FB6	7.0 - 16.0	R = 2.0
BMD-FB10	15.0 - 18.0	R = 1.0
	> 18.0 - 150.0	R = 1.5
BMD-ME	-	R = 4.5
BMD-PK (Series 10)	-	R = 2.5
BMD-PK (Series 6)	7.9 - 20.0	R = 2.0
BMD-3P (Series 10)	-	R = 2.5
BMD-3P (Series 6)	8.0 - 20.0	R = 2.0



Ruby contact points (MRU) (extra charge)

For non-ferrous metals, aluminium and their alloys.

It may be necessary to opt for diamond contacts when working with very soft aluminium materials, etc.

contact point radii, see table MHM

Hardness ruby: approx. 2000 HV

Order suffix: MRU

Example:

BMD-S10-35.0-MRU

Not available for Series 4 and FB

Diamond contact points (MDI) (extra charge)

Suitable for use with extremely soft aluminium materials, under heavy wear conditions (e.g. automatic measurement) and with highly polished surfaces, etc. These contact points are made of natural diamond (available for nominal diameters of 3,95 and above).

Please note: The contact point may be damaged while working with sharp-edged workpieces. Please inquire before using the MB-SO extended range option. MDI contacts not available for series FB6 and FB10.

Plastic contact points (MKK) (extra charge)

These gauging contacts should be used only under certain specific conditions, e.g. for highly polished surfaces.

The contact points consist of polyamide balls (Ø 4.0 mm). These elements can be replaced by the customer.

Available for nominal diameters of 25.0 mm and above. Type S or D only.

Maximum measurement range: MB-SO+0.3

Order suffix: MKK





Example:

BMD-S10-CR-35.0-MKK

Service life

Service life depends upon such conditions as workpiece surface quality (roughness, coating), material, length of the measured bore, measuring pressure, etc. Up to 1,000,000 measurements are possible under optimum conditions.

The following options may be selected for applications involving heavy wear conditions:

- Air cleaning (L)  13
- PG  8
- MDI  7
- PK-ZHML  14
- measuring pressure reduction  6

Protective cover AD

(extra charge)

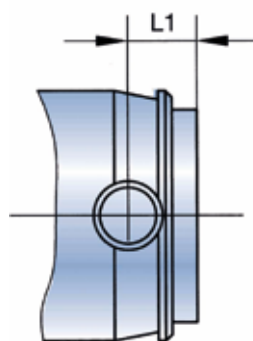

Protective covers should be used with caution. Covers protect mechanical parts and reduce the risk of dirt accumulation. However, they make it difficult to remove chips, coolants and other deposits.

Standard protective covers are made of aluminum. Covers made of steel, hardened steel and other materials are available on request. Depending on nominal diameter and design, protective covers are either glued or screwed in place.

Covers for types S and S-FB

Covers for type S are available for nominal diameters of 4.0 and above. Up to a nominal diameter of 28.0, the dimension L1 increases by 0.5 mm. For nominal diameters of 28.0 and above, dimension L1 increases by 2.0 mm.

Order suffix: AD-S

Example:

BMD-S10-CR-35.0-AD-S

Covers for type D

Dimension L1 increases by 1 mm. Order suffix: AD-D

Example:

BMD-D10-CR-35,0-AD-D

Covers for type FB

BMD-FB6: Dimension L1 increases by 0.5 mm. For series BMD-FB10, nominal diameters 15-28 mm, dimension L1 increases by 0.5 mm and for nominal diameters of 28 mm by 2 mm.

Order suffix: AD-FB

Example:

BMD-FB10-CR-35.0-AD-FB

Contact points diamond (MDI)

BMD series	Diameter range	Gauging radius
Series 4	3.95 - 9.0	R = 0.5
Series 6	7.0 - 16.0	R = 2.0
Series 10	15.0 - 270.0	R = 2.5
Order suffix	MDI	
Example	BMD-S10-CR-35.0-MDI	



Reduced cylinder diameter tolerance (MZ) (extra charge)

The manufacturing tolerances for guide cylinders indicated for BMD types S and D (10/11) are reduced to 0.01 mm (± 0.005). The purpose is to reduce axial and radial errors to a minimum. This option should be used only for very small bore tolerances (to approx. 0.01 mm).

Cylinder production tolerance (min. bore diameter -0.01) ± 0.005 mm

Order suffix: MZ

The MZ dimension is approx. 0.01 mm lower than the minimum bore diameter (= nominal BMD diameter).

Example:

Min. bore diameter = 35.0

MZ diameter = 34.99

BMD-S10-35.0-MZ-34.99

The guide cylinder is manufactured with a diameter of $\varnothing 34.99 \pm 0.005$ mm

Range of application

$\varnothing 4,0 - 100,0$ mm.

Other diameter dimensions on request.

BMD without inherent gauging pressure (PG)

Without an indicator, BMD plugs have an inherent gauging pressure of approx. 0.2 – 1.7 N.

In option PG – without inherent gauging pressure – the built-in probe is not pre-extended.

The contact points are retracted beneath the surface of the guide cylinder. This option should be selected e.g. for use with sensitive or rough workpiece surfaces.

Please note:

Indicator gauging pressures must be higher, as the probe exerts no pressure of its own.

Option PG should be used in conjunction with the following accessories:

Holders:

MH-6-73-R  24

MH-10-150-R  25

MH-10-150-PG  32

Order suffix: PG

Example:

BMD-S10-35.0-PG

Toleranced connecting length (AT0) (extra charge)

Depending on how the gauging unit is installed, the needle may protrude at different lengths (differences of up to 1.0 mm). Especially when electronic probes are used, the gauge has to be readjusted in the holder when the plug gauge is changed (electrical zero point). In order to avoid this problem, the dimension from the stop collar to the needle is adjusted with a tolerance of ± 0.02 in option AT0. The adjustment is made in the setting ring at the nominal dimension. This option requires that the setting ring be ordered with the component.

Please note:

If the plug gauge is used with such accessories as depth extensions, right angle attachments, etc., option AT0 must cover the entire unit (accessories are not interchangeable).

BMD series	AT0
Series 4	12.55 ± 0.02
Series 6	12.18 ± 0.02
Series 10	21.96 ± 0.02

Order suffix: AT0

Example:

BMD-S10-35.0-AT0

BMD-S10-35.0+TV-15-64-AT0

Note:

Dimension AT0 changes as a result of mechanical wear.

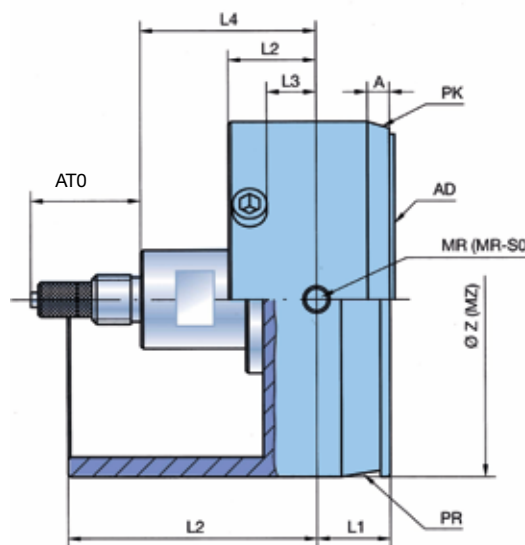
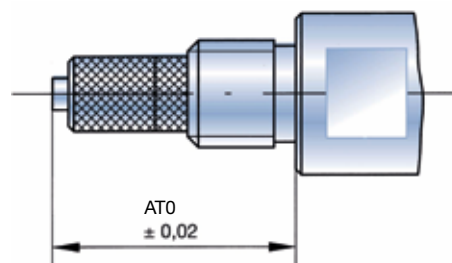

Inspection plug gauge (BM) (on request, extra charge)

The inspection plug gauge is a full-form GO gauge used to measure minimum bore diameter. If the inspection gauge can be inserted into the bore, the exact actual diameter as well as any shape defects are shown on the indicator.

Series 6 $\varnothing 8.0 - 20.0$

Series 10 $\varnothing >20 - 100.0$

Quality ISO6 or to customer specification

Important dimension-based codes for special types

A	Length of pilot taper 15°/30° (14)
AD	Cover AD-S, AD-D
AT0	toleranced connecting length
L1	Length from contact midpoint to BMD face
L2	Length from contact midpoint to cylinder end
L3	Length from contact midpoint to depth stop
L4	Length from contact midpoint to end of threading
MB-B	Measurement range limitation
MB-SO	Extended measurement range
MZ	Limited Z dimension
MR-SO	Special gauging contact radii
ØZ	Actual diameter of BMD cylinder



In diameters of up to 44.0 mm, the guide cylinder and the threaded connection fittings are produced as a single part. In plug gauges with nominal diameters larger than 44.0 mm, guide cylinders and the threaded connection fittings are manufactured as separate parts.

The basic plug gauge types are generally used as manual measuring device and are thus produced with entry grooves which prevent the gauge from jamming as it enters the bore. Series 4 BMD have no entry grooves.



Our Basic plug gauge types are divided into three groups:

1. Basic plug gauge for general-purpose gauging

Due to its short L1 dimension, this type is not suitable for measurement from the lip of the bore (☞ 10).

2. Basic plug gauge for all through bores

This type of plug gauge should always be used for workpieces with through bores. Another advantage is that the enlarged L1 dimension allows reliable measurement from the lip of the bore (☞ 11).

3. Basic plug gauge for blind bores

This type of BMD should always be used when measurements are to be made near the bottom of the bore or when bores are very short. For very short bores, the entry groove should be reduced in size or eliminated entirely (Type OR). The BMD-FB plug gauge is produced in versions FB-6 (connection threading M6 x 0.75) and FB-10 (connection threading M10 x 1) and is available in nominal diameters of 7.0 mm and above (☞ 12). Smaller bore diameters require the use of Type BMD-S4-S-FB.

Insertion aids

In order to facilitate insertion of the plug gauge into the bore, DIATEST offers optional entry grooves (PR) and pilot tapers (PK). An entry groove is the standard solution for preventing jamming during manual measurement. For automatic measurement or use in measuring systems, the pilot taper is used in conjunction with a floating holder (see ☞ 47). For very short bores (in which an entry groove cannot be used) the cylinder is bevelled (Option OR, see ☞ 15).

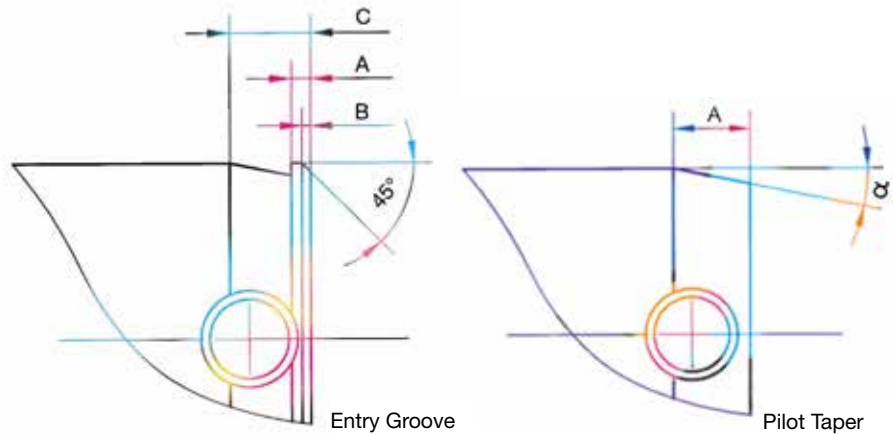

Entry groove dimensions

Series	Nom. diameter range	A	B	C
6	> 7.0 - 10.0	0.5	0.3	1.9
6	> 10.0 - 20.0	0.6	0.3	2.0
10	> 15.0 - 25.0	0.9	0.5	3.7
10	> 25.0 - 44.0	1.1	0.5	4.6
10	> 44.0 - 70.0	1.5	0.5	6.5
10	> 70.0 - 100.0	2.0	0.5	10.0
10	> 100.0 - 270.0	2.0	0.5	11.0

Pilot taper dimensions (PK)

Series	Nom. diameter range	Type D		Type S / S-FB		
		A	α	A (S)	A (S-FB)	α
4	> 3.95 - 6.0	1.5	8°	0.4	-	30°
4	> 6.0 - 9.0	3	8°	0.8	-	30°
6	7.0 - 9.0	3.5	8°	2.5	1,1	15°
6	> 9.0 - 20.0	3.5	15°	2.5	1,1	15°
10	15.0 - 70.0	4	15°	3	1,9	15°
10	> 70.0 - 270.0	4.5	15°	3.5	1,9	15°

Typ S4-S-FB and FB: on request

Sample applications for 2-point and 3-point BMD



2-point plug gauges for standard applications (bore diameter, shape deviations), special: oval



3-point plug gauges: for polygon only

S4

Nominal diameter range: Ø 2.98 - 9.0 mm

Ø Z = Nom. diameter - 0.02 / - 0.04

Sample order:

Bore diameter	Order Code
7 D6	BMD-S4-CR-7.04

Diameters less than 2.98 with T-BMD (17)

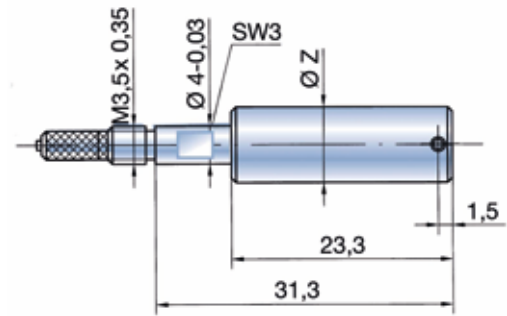

S6

Nominal diameter range: 7.0 - 20.0 mm

Ø Z = Nom. diameter - 0.02 / - 0.04

Sample order:

Bore diameter	Order Code
10 H6	BMD-S6-CR-10.0

Nom. diameter	7.0 - 8.0	> 8.0 - 20.0
Ø D	6.8	7.9
SW	6	7

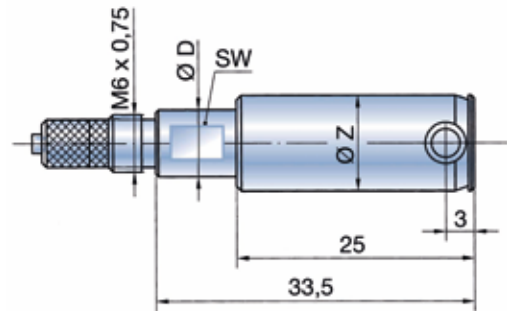

S10

Ø 15 - 44 mm

Nominal diameter range: above 15.0 - 44.0 mm

Nom. diameter Ø 15 - 32.0

Ø Z = Nom. diameter - 0.02 / - 0.05

Nom. diameter Ø > 32 - 44.0

Ø Z = Nom. diameter - 0.03 / - 0.06

Sample order:

Bore	Order Code
40 - 0.007 / + 0.025	BMD-S10-CR-39.993

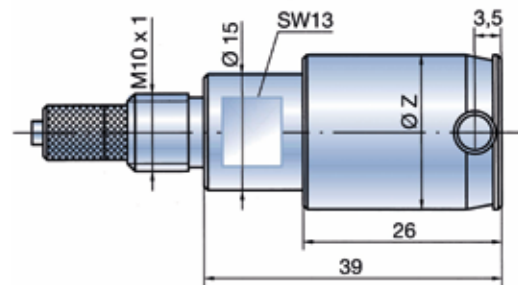

S10

Ø > 44 - 70 mm

Nominal diameter range: above 44.0 - 70.0 mm

Ø Z = Nom. diameter - 0.03 / - 0.06

Sample order:

Bore	Order Code
50 R7	BMD-S10-CR-49.95

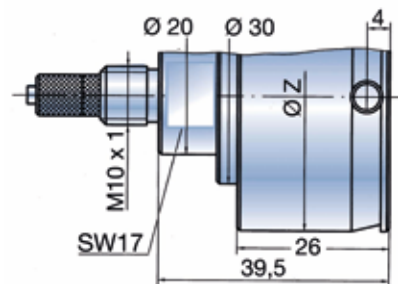

S10

Ø > 70 - 270 mm

Nominal diameter range: above 70.0 - 270.0

Nom. diameter > 70 - 200

Ø Z = Nom. diameter - 0.04 / - 0.07

Nom. diameter > 200 - 270

Ø Z = Nom. diameter - 0.06 / - 0.10

Sample order:

Bore	Order Code
125 - 0.04	BMD-S10-CR-124.96

Nominal diameters over Ø 270 mm on request

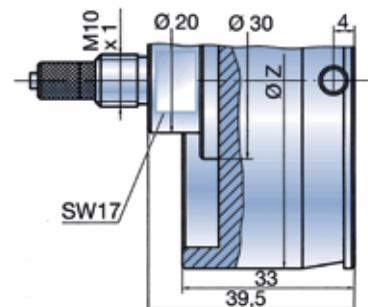

D4

Nominal diameter range: \varnothing 2.98 - 9.0 mm

\varnothing Z = Nom. diameter - 0.02 / - 0.04

Sample order:

Bore diameter	Order Code
5 N8	BMD-D4-CR-4.98

Diameters less than 2.98 with T-BMD (17)

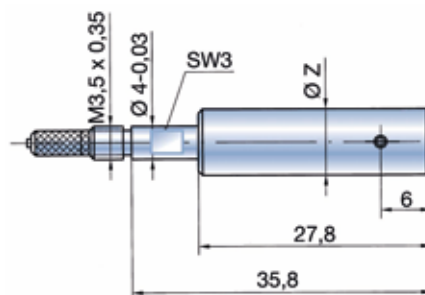

D6

Nominal diameter range: 7.0 - 20.0 mm

\varnothing Z = Nom. diameter - 0.02 / - 0.04

Sample order:

Bore	Order Code
10 + 0.04	BMD-D6-CR-10.0

Nom. diameter	7.0 - 8.0	8.0 - 20.0
\varnothing D	6.8	7.9
SW	6	7

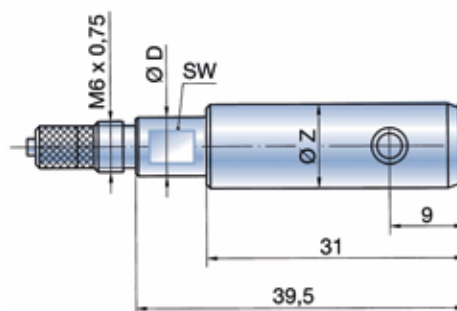

D10 \varnothing 15 - 44 mm

Nominal diameter range: above 15.0 - 44.0 mm

Nom. diameter \varnothing 15 - 32.0

\varnothing Z = Nom. diameter - 0.02 / - 0.05

Nom. diameter \varnothing > 32 - 44.0

\varnothing Z = Nom. diameter - 0.03 / - 0.06

Sample order:

Bore	Order Code
42 K8	BMD-D10-CR-41,97

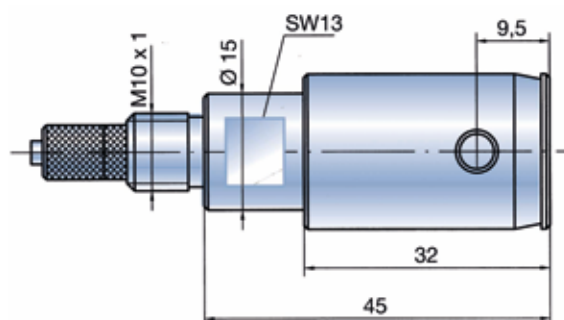

D10 \varnothing > 44 - 70 mm

Nominal diameter range: above 44.0 - 70.0 mm

\varnothing Z = Nom. diameter - 0.03 / - 0.06

Sample order:

Bore	Order Code
60 JS8	BMD-D10-CR-59.777

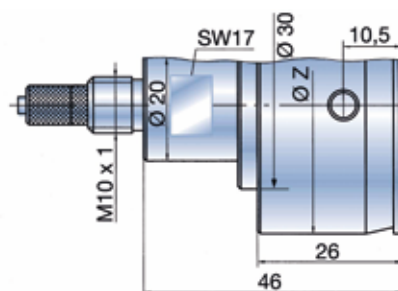

D10 \varnothing > 70 - 270 mm

Nominal diameter range: above 70.0 - 270.0 mm

Nom. diameter > 70 - 200

\varnothing Z = Nom. diameter - 0.04 / - 0.07

Nom. diameter > 200 - 270

\varnothing Z = Nom. diameter - 0.06 / - 0.10

Sample order:

Bore	Order Code
100 H7	BMD-D10-CR-100.00

Nominal diameters over \varnothing 270 mm on request

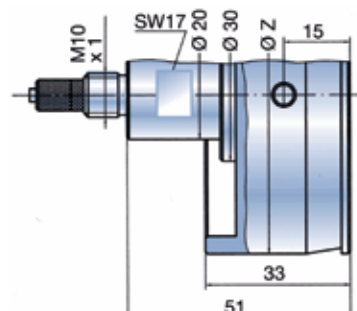

We recommend version PG for BMD type FB (see 8)

FB6 Ø 7,0 - 16,0 mm

Nominal diameter range: above 7.0 - 16.0 mm

Nom. diameter Ø 7.0 - 16.0
 Ø Z = Nom. diameter - 0.02 / - 0.04

Sample order:

Bore	Order Code
9 K8	BMD-FB6-CR-8.984

Contact points only available in MHM or MCR

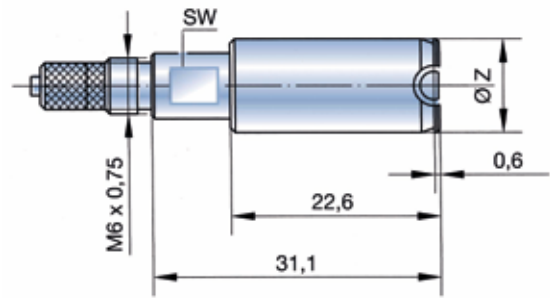

FB10 Ø 15,0 - 44,0 mm

Nominal diameter range: above 15.0 - 44.0 mm

Nom. diameter Ø 15.0 - 32.0
 Ø Z = Nom. diameter - 0.02 / - 0.05

Nom. diameter Ø > 32 - 44.0
 Ø Z = Nom. diameter - 0.03 / - 0.06

Sample order:

Bore	Order Code
42 K8	BMD-FB10-CR-41.973

Contact points only available in MHM or MCR

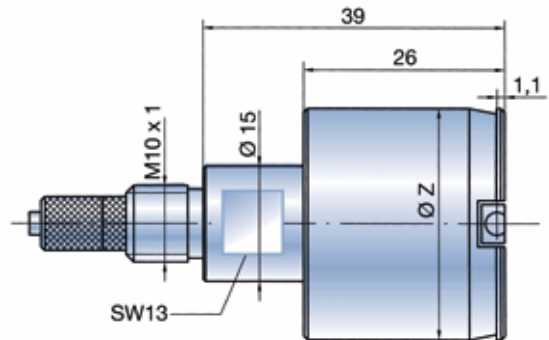

FB10 > Ø 44,0 - 70,0 mm

Nominal diameter range: above 44.0 - 70.0 mm

Ø Z = Nom. diameter - 0.03 / - 0.06

Sample order:

Bore	Order Code
60 JS8	BMD-FB10-CR-59.977

Contact points only available in MHM or MCR

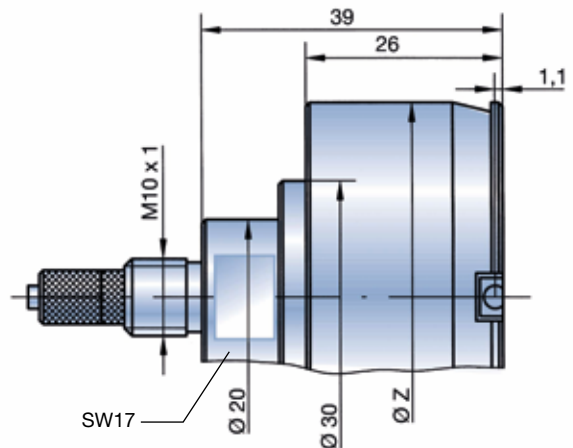

FB10 > Ø 70,0 - 150,0 mm

Nominal diameter range: above 70.0 - 150.0 mm

Ø Z = Nom. diameter - 0.04 / - 0.07

Sample order:

Bore	Order Code
100 H7	BMD-FB10-CR-100.00

Contact points only available in MHM or MCR

Nominal diameters over Ø 150 mm on request

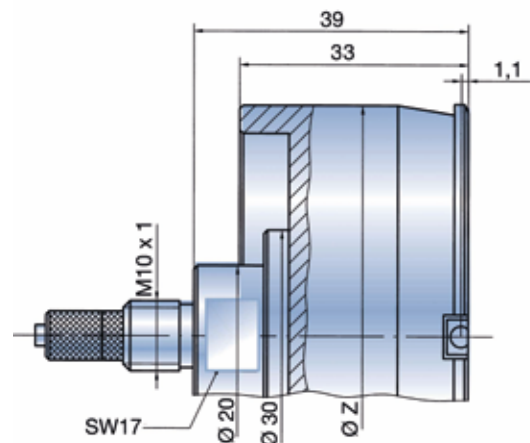

DIATEST exclusively produces plug gauges with mechanical measurement systems. Type L (air supply) gauges are designed to provide for workpiece cleaning at the contact points and

to reduce contact bore fouling. All gauges equipped with an air cleaning system are produced with covers. This increases dimension L1.

DIATEST supplies an aluminum cover as a standard component. All dimensions not otherwise specified are the same as for basic types S and D. Required air pressure: 2-3 bar.

Accessories for BMD-L: Holders L-MH10-150 (30), Depth extensions L-TV8, L-TV15, L-TV15-A (37/38), Right-angle attachments L-W10 (36), Adapter A6-10-L (35)

L-S6 Ø 7,0 - 20 mm

L-D6 Nom. diameter range: 7.0 - 20.0 mm

Covers for Series L-S6 are glued into place
 Type S L1 = 3.5 mm
 Type D L1 = 9.5 mm

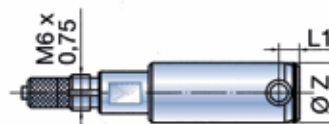

L-S10 > Ø 15 - 44 mm

L-D10 Nom. diameter range: 15.0 - 44.0 mm

Covers for Series L-S10 up to nom. diameter of 28.0 mm are glued into place.
 Type S10 > 28 mm and Type D are bolted in place
 Type S Ø 15.0 - 28.0 mm L1 = 4.0 mm
 Ø > 28.0 - 44.0 mm L1 = 5.5 mm
 Type D L1 = 10.5 mm

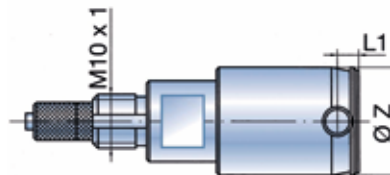

L-S10 > Ø 44 - 70 mm

L-D10 Nom. diameter range: 44.0 - 70.0 mm

Cover bolted
 Type S L1 = 6.0 mm
 Type D L1 = 11.5 mm

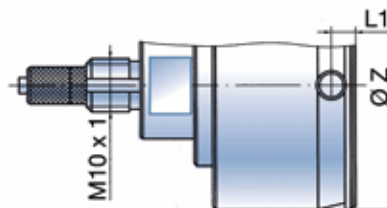

L-S10 Ø 70 - 270 mm

L-D10 Nom. diameter range: 70.0 - 270.0 mm

Cover bolted
 Type S L1 = 6.0 mm
 Type D L1 = 16.0 mm

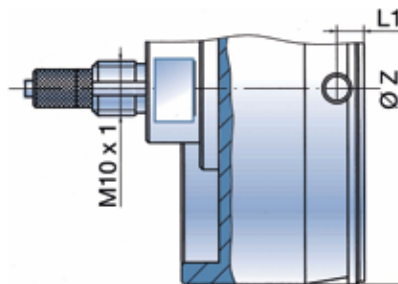

L-FB6 Ø 7 - 16 mm

Nom. diameter range: 7.0 - 16.0 mm

Cover glued

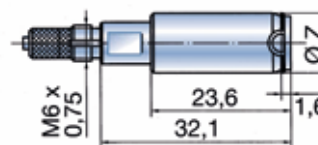

L-FB10 Ø 15 - 150 mm

Nom. diameter range: 15.0 - 150.0 mm

Covers glued up to nom. diameter 28.0 mm, bolted above 28.0 mm.

Ø 15 - 28 L1 = 1.6 mm
 Ø > 28 - 150 L1 = 3.1 mm

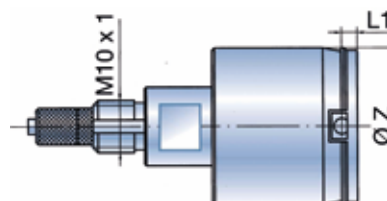



BMD for automatic gauging - Type PK – are produced with a 30° or 16° pilot taper instead of an entry groove. With the aid of matching floating holders, these BMD can be used in measuring systems, transfer lines, CNC machines and auto-

mated testing units, etc. Type D plug gauges should be used wherever possible:

- Longer pilot taper (= larger floating range)
- The gauging contacts are positioned behind the pilot taper,

which makes it easier to insert the contacts into the bore (especially for MB-SO), thus reducing wear. In type S gauges, the contacts are partially inside the taper. Unless otherwise specified,

dimensions correspond to those of the basic types. In the version with air supply – L – dimension L1 is enlarged for the protective cover as indicated in the specification on 7.

Series	Nom. diameter range	Type D			Type S			2Z Nom. diameter minus	Gauging radius R	Threading G
		A	B	α	A	B	α			
4	3.95 - 6.0	1.5	9	16°	0.4	8	60°	0.2	0.5	M 3.5 x 0.35
4	> 6.0 - 9.0	3	9	16°	0.8	8	60°	0.2	0.5	M 3.5 x 0.35
6	7.9 - 9.0	3.5	12	16°	2.5	11	30°	0.3	2	M 6 x 0.75
6	> 9.0 - 20.0	3.5	12	30°	2.5	11	30°	0.3	2	M 6 x 0.75
10	15.0 - 70.0	4	14	30°	3	13	30°	0.4	2.5	M 10 x 1
10	> 70.0 - 270.0	4.5	18	30°	3.5	17	30°	0.4	2.5	M 10 x 1

PK

BMD with pilot taper

Standard type (no extra charge)

- Basic types: S, D, L
- Nom. diameter range: 3.95 - 270 mm
- Order suffix: PK
- Sample order: BMD-D10-CR-30.0-PK
- Ø Z as in basic types

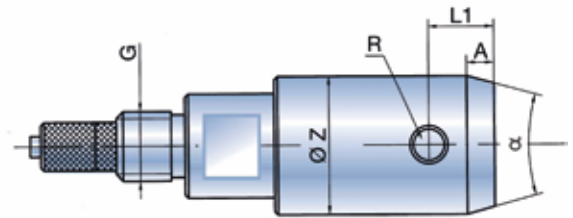

PK-2Z

BMD with pilot taper and bevelled cylinder (extra charge)

The bevelled cylinder reduces the risk of jamming resulting from deviation of plug gauge angle to the bore axis.

- Basic types: S, D, L
- Nom. diameter range: 3.95 - 270 mm
- Order suffix: PK-2Z
- Sample order: BMD-D10-CR-30.0-PK-2Z-Ø 2Z = 30 - 0.4 mm
- Ø Z as in basic types

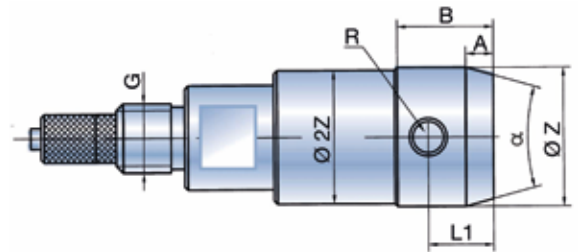

PK-ZHML

BMD-PK with carbide bars (PK-ZHML) (extra charge)

Carbide bars reduce the risk of jamming in fouled bores (e.g. chips in bore).

- Basic types: S, D, L
- Nom. diameter range: Series 6 Ø 11 - 20 mm
Series 10 Ø 18 - 270 mm
- Ø D Series 6 Nom. diameter - 2 mm
Series 10 Nom. diameter - 3 mm

- Ø Z as in basic types
- BMD gauge cylinder in OCR
- Order suffix: PK-ZHML
- Sample order: BMD-D10-OCR-30.0-PK-ZHML

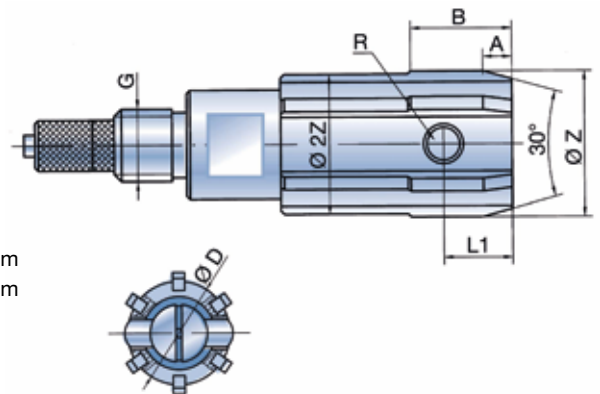

Special-purpose plug gauges are designed to meet specific customer needs. These include either customized products

(indicated by “on request”) or modifications of basic cylinder types (indicated by “extra charge”).

All special types must be specifically requested. Your request should include a precise description of the measurement problem

and a reliable drawing illustrating the measurement problem. A sample workpiece may be necessary in some cases.

S-FB

BMD for blind bores (extra charge)

In order to measure closer to the bottom of the bore, the guide cylinder of type S or FB is shortened.

L1-dimensions that lie between the minimum length L1 and the standard must be indicated in the order.

Type S

Nom. diameter range: Ø 4.0 - 270.0 mm

Advantages of type S-FB

The large gauging radii of type S are used. This facilitates insertion of the plug gauge into the bore and helps to reduce wear.

Ø Z = nom. diameter same as for type S. L2 same as for type S

BMD gauge type	Min. length L1
Series 4	0.6 mm (Ø 4.0 and above*)
Series 6	1.6 mm
Series 10	2.4 mm

*) for Ø < 4,0 type T-BMD-FB can be realized

Series 10 – 3P: L1=3.0

Series 6 – 3P: L1=2.0

FB-S-FB

Nom. diameter range: 15.0 – 150.0 mm

Ø Z = nom. diameter as in type FB.

Minimum length L1 = 0.5 mm.

At L1 = 0.5 mm, the gauging contact has a sharp edge, which results in heavier wear. If the workpiece is also sharp-edged, Option PG should be used (☐ 8). Available only in type BMD-FB10.

Order suffix: S-FB

Sample order:

Bore	Order Code
28 H7 requested L1 = 3.0	BMD-S10-CR-28.0- S-FB-L1 = 3.0

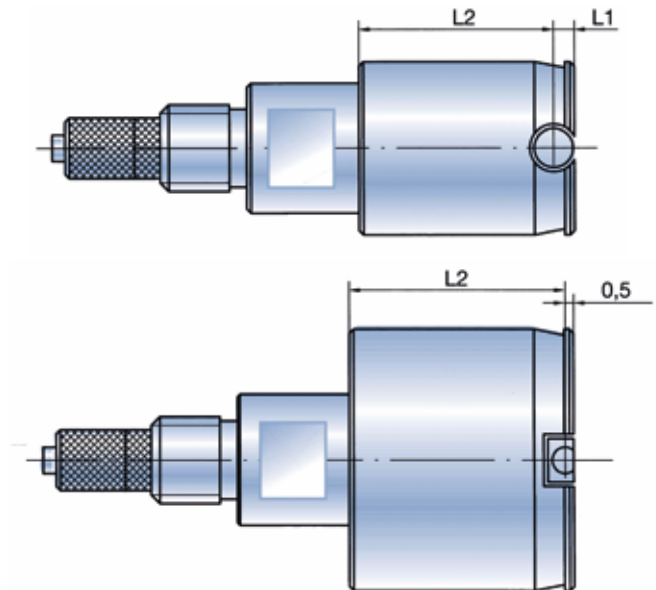

OR

BMD without entry groove

(no extra charge)

When used in very short bores, the entry groove cancels out most or all of the guide function.

Order suffix: OR

Sample order:

Bore	Order Code
30 H6	BMD-S10-CR-30.0- OR-chamfer 0.5 x 45°

In this case, use of an entry groove is not recommended. The cylinder should be bevelled in order to prevent jamming. Basic types: S, D, FB, S-FB, L

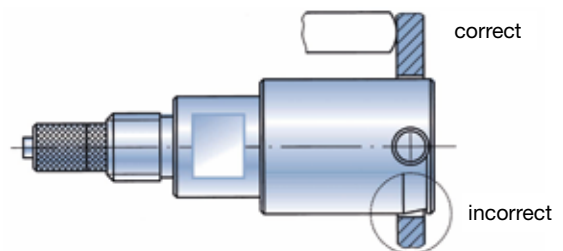

UM

BMD with reduced entry diameter

(extra charge)

Nom. diameter range: 7.9 – 270 mm

The BMD can be inserted to the end of the front cylinder before the finished dimension is reached, thus making it possible to gauge the machine stop point. The entire BMD can be inserted into the bore beyond the finished dimension.

Basic types: S, D Order suffix: UM

Sample order:

Bore	Order Code
30 H7	BMD-S10-CR-30.0-UM

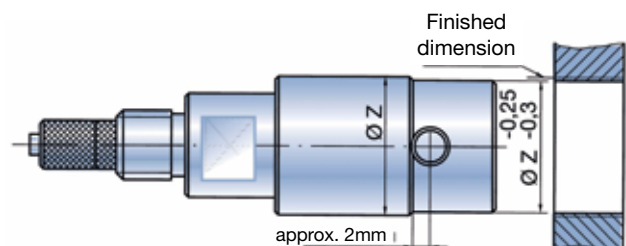

2R

BMD with 2 entry grooves

(extra charge)

This option prevents jamming when the BMD is retracted from ribbed workpieces or interrupted bores.

Basic types: S, D, FB, S-FB, L
 Nom. diameter range: 7.0 - 270 mm
 Order suffix: 2R

Sample order:

Bore	Order Code
10 H6	BMD-S6-CR-10.0-2R

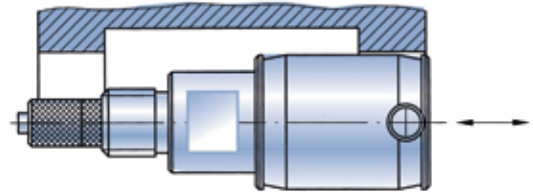

3P

3-point BMD (extra charge)

3-point plug gauges are required in order to detect polygonal shape defects.

The gauging contacts are spaced at 3 x 120°. Different spacing available on request.

The inner probe is mounted on a pendulum bearing in order to allow the gauging unit to center itself in the bore.

Basic types: S, D, L
 Diameter range: 8.0 - 100 mm
 Sample order: BMD-S10-CR-35.0-3P

The dimensions of the BMD correspond to those of the basic types in Series 6 and 10.

Due to its specific design, the gauging accuracy of the 3-point BMD is slightly less than that of the 2-point gauge (see 5). Therefore, a 2-point plug gauge should be used wherever possible.

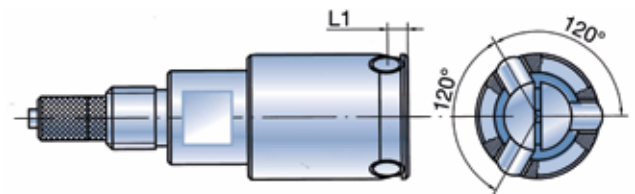

SO-TA

BMD with depth stop (extra charge)

3 carbide stop bolts set at 3 x 120° angles.

Basic types: S, D, S-FB, L-FB, FB
 Order suffix: SO-TA-L3
 Sample order: BMD-D10-CR-28.0-SO-TA-L3 = 11

Please indicate dimension L3 in your order.

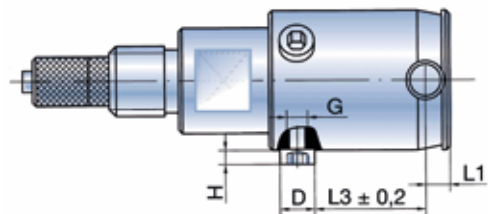

Table for SO-TA

Nom-Ø	Type	max. L3	Type	max. L3	D	H	G
12 - 20	S6	16	D6	16	5	2	M3
20 - 32	S10	16.5	D10	16.5	5	2	M3
> 32 - 44	S10	16.5	D10	16.5	7.5	3.5	M5
> 44 - 70	S10	14.5	D10	8	7.5	3.5	M5
> 70 - 270	S10	21.5	D10	10.5	7.5	3.5	M5

T-BMD

BMD for small dimensions

(extra charge)

Types: Standard, FB and PA

Nom. diameter ranges:

Standard, FB $\varnothing > 2.0 - 3.0$ PA II $1.0 - 3.0$ $\varnothing Z = \text{Nom. diameter} - 0.02/-0.04$

Standard, FB

Nom. diameter	LM	L1	L1 (FB)	L
$\varnothing 2.0 - 2.50$	21.5	1.1	0.5	30.5
$\varnothing > 2.50 - 3.0$	27.0	1.4	0.5	35.8

PA

Nom. diameter	LM	L1	L1 (FB)	L
II $1.0 - 1.5$	4.5	0.8	-	24.7
II $> 1.5 - 2.49$	4.5	1.1	0.5	30.5
II $> 2.49 - 3.0$	4.5	1.4	0.5	35.8

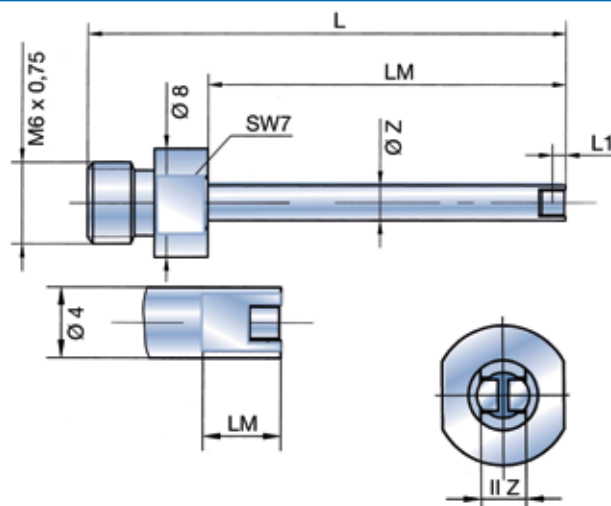

Gauging contacts:

FB: only in MCR

Standard: MHM and MCR

PA: with MCR, from II 1.51 also MHM

Measurement range: + 0.15 mm

Sample order: T-BMD-2.55 · T-BMD-PA-2.38

ZKUL

BMD with plastic bars (on request)

Designed for use with very sensitive surfaces (e.g. polished hydraulic bores, etc). MDI or MKK gauging contacts may be required.

Basic types: S, D, L

Nom. diameter ranges: Series 6 $\varnothing 11 - 20$ mmSeries 10 $\varnothing 18 - 270$ mm $\varnothing D$ Series 6 Nom. diameter - 2 mm

Series 10 Nom. diameter - 3 mm

 $\varnothing Z$ same as for basic types

Order suffix: PK-ZKUL

Sample order: BMD-D10-OCR-30.0-PK-ZKUL

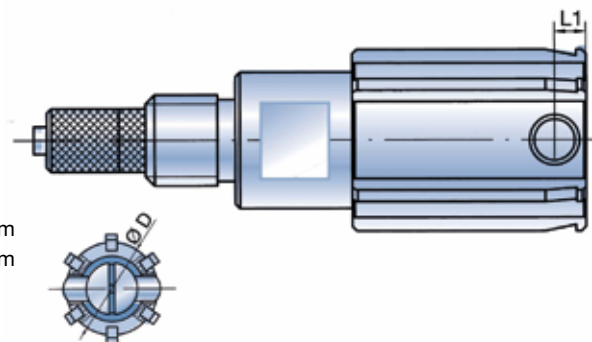

SO-DZL

BMD with long cylinder (extra charge)

In versions with air supply - L - length L1 increases by 1 mm.

Basic types: D, L

Nom. diameter ranges: 3.95 - 44 mm

Sample order: BMD-S6-CR-10.0-SO-DZL

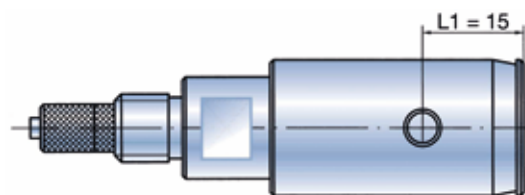

SO-ZL

BMD with extended cylinder (on request)

Basic types: S, D, L

Nom. diameter ranges: $\varnothing 3.95 - 270$ mm

For requests, please mention the following lengths:

L1 max. 200 mm

L2 up to nom. diameter 23.0 max. as in L4

Nom. diameter > 23.0 max. 200 mmL4 **cannot be changed**

Sample order:

BMD-S10-CR-39.997-SO-ZL-L1 = 25-L2 = 50

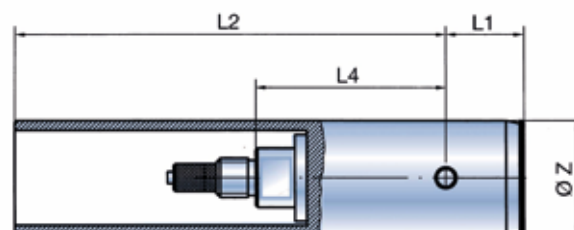

For large L2 lengths, a TV15 depth extension may be required.

SO-KO

BMD for tapered bores (on request)

All BMD-SO-KO plug gauges must be used with a depth stop (e.g. SO-TA, etc.). When ordering with an SO-TA, please indicate length L3.

The BMD can only be produced on the basis of a tapered master ring or a good sample workpiece with corresponding minimum tolerance.

Clearance A is approx. 0.05 mm at minimum bore diameter. Please furnish a workpiece drawing with inquiry.

Basic types:	S, D, FB, S-FB, L
Nom. diameter range:	4 - 100 mm
Max. angle:	approx. 30°

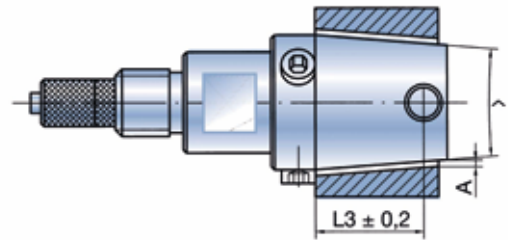

SO-2Z

BMD with 2 guide cylinders

(on request)

Type SO-2Z is used to reduce centering errors when working with short bores by using a second bore for support.

Basic types:	S, D, FB, S-FB, L
Nom. diameter range:	3.95 - 270 mm
Sample order:	BMD-S10-CR-49.95-SO-2Z-Ø Z1 = 55.0-L3' = 5

Please furnish a workpiece drawing with inquiry.

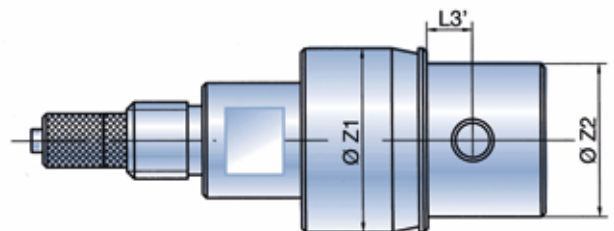

SO-GL

BMD with axial grooves (on request)

The guide pins (1) secure the radial position of the gauging contacts in the groove or the core bore.

Please order the data sheet for SO-GL before placing your request.

Basic types:	S, D, FB, L
Nom. diameter range:	6.0 - 270 mm

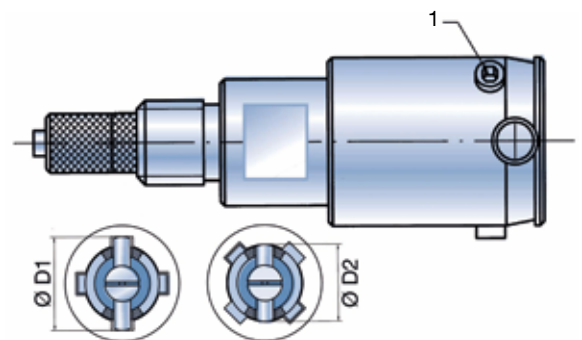

SO-FB-SO

BMD-FB plug gauges for stepped bores

(on request)

This gauge type is ideally suited for measuring stepped bores close to the step. The large gauging radii ($R = 2.5$) are ideal for measuring bores with rough surfaces*.

Please indicate the following in your order:

L1' : Distance from gauging contact midpoint to step (min. 0.5 mm)

L1 : Standard as for type S or D

ØD : Diameter of the staggered cylinder

Basic types:	S, D
Nom. diameter range:	7 - 270 mm
Sample order:	BMD-S10-CR-35.0-SO-FB-SO-L1' = 0.5-ØD = 33.0

BMD-S10-CR-35.0-SO-FB-SO-L1' = 0.5-ØD = 33.0

* Please use type PG (8) if possible.

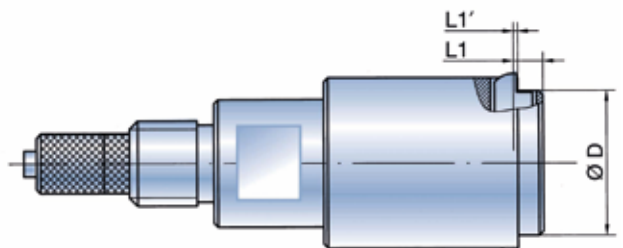

SO-KW

BMD for crankshafts (on request)

For measuring face distance F of connecting rod bearing surface on crankshafts, camshafts, etc.

Nom. diameter range: 8 - 100 mm

Types: Type S or FB

Distance: shaft – measuring point X:

Type FB: X min. 1.6 mm

Type S: X min. 2.9 mm

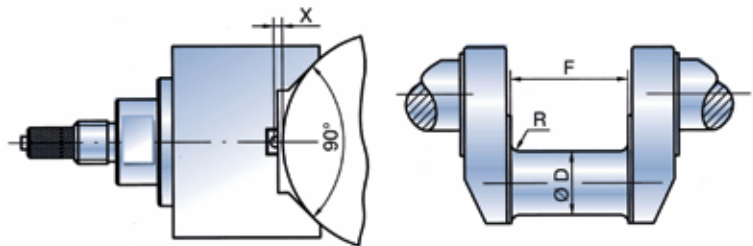

Please indicate the following values in your inquiry: Dimension F (with tolerance), R, Ø D, X or request data sheet SO-KW.

Available in OCR only.

SO-SZ

BMD with special cylinder shapes (on request)

Please enclose a detailed drawing with all requests for gauges of this type.

Basic types: S, D, FB, L, S-FB

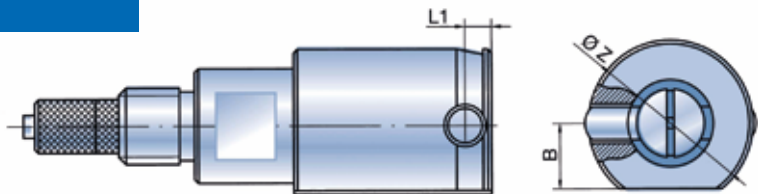

SO-PA

BMD for parallel distances, customized versions (on request)

For distance measurement in workpieces for which the standard BMD PA cannot be used.

Basic types: S, D, FB, L, S-FB

Nom. size range: 4 - 270 mm

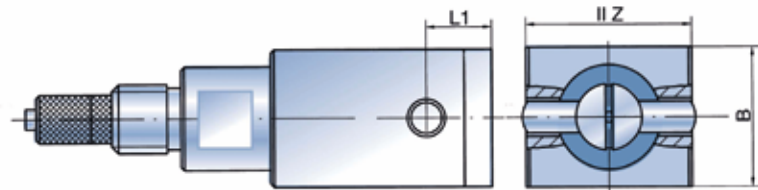

Type SO-PA in OCR only

EMD

BMD for recess gauging (on request)

Plug Gauge for gauging recesses in workpieces from 20 mm. Measuring range from 3,5 to 10 mm (depending on nominal size). Contact points available in carbide (MHM) and chrome (MCR). Please furnish workpiece drawing with inquiry.

Table of measuring range

diameter of bore	max. travel in relation to Ø (results in recess diameter)
20 - 21	3.5
> 21 - 22	4.0
> 22 - 24	4.5
> 24 - 26	5.0
> 26 - 28	5.5
> 28 - 30	6.0
> 30 - 34	7.0
> 34 - 36	8.0
> 36 - 40	9.0
> 40	10.0

Remark: This table is only a rough guideline; deviations depending on shape of workpiece are possible

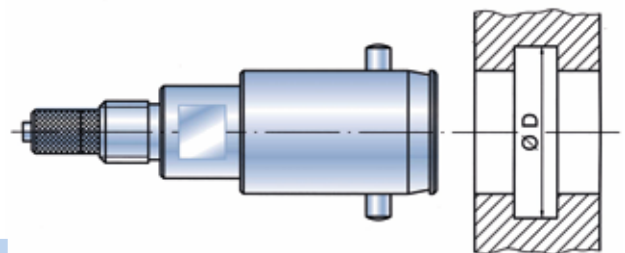

BMD-OD

BMD for measuring outside diameter (on request)

Plug gauge used to measure outside diameters of $\varnothing D$ between 20 and 100 mm.

Max. measuring depth version 1: 10 mm

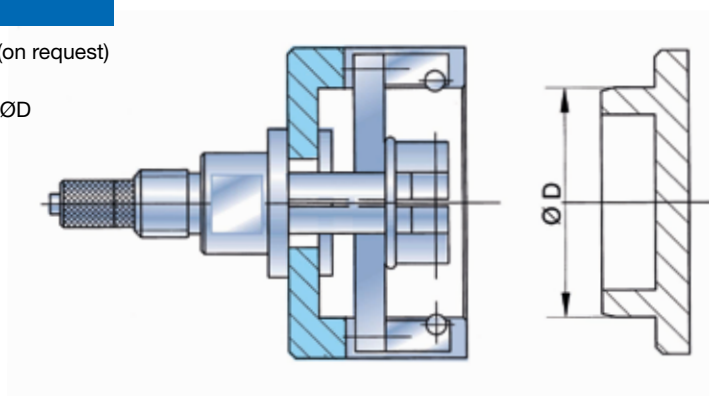

Max. measuring depth version 2: 30 mm

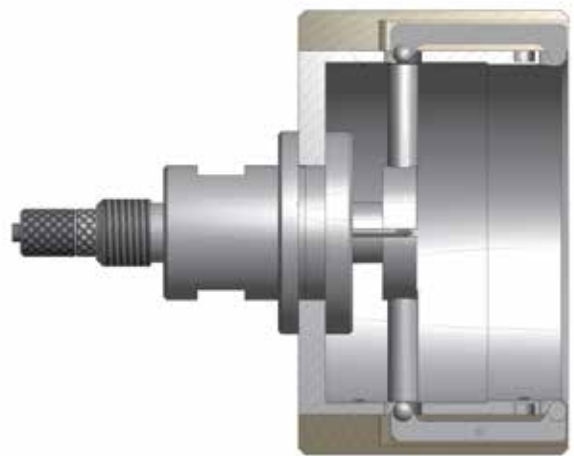

Please enclose a workpiece drawing with your enquiry.
We require a sample workpiece or a setting master for production.

BMD-IV

Ø Zylinder 10 - 100 mm**BMD for internal gear gauging** (on request)

Measuring of distance between balls (M_i)

Guiding cylinder is adapted to internal \varnothing of gears. Guiding noses avoid turning of BMD inside the work piece.

Requests required with drawing of workpiece and data about gears: measure M_i , diameter of balls, number of teeth.

For production, we need a GO-workpiece or a setting master with full tooth system. Production is not possible without workpiece or fully toothed setting master!

Versions: type S- or D, special cylinders over \varnothing 10 mm.



Type PA BMD are hybrid constructions composed of a BMD and a probe: Modified versions of probes from our probe programme are mounted in a guide cylinder. The carbide steel guide cylinder (approx. 62 HRC) is available only in OCR Gauging contacts are

supplied in MCR and – depending on size – also in MHM. For pricing, please note that the price of the needle is added to the price of the BMD for Type PA units.

Required accessories:

- BMD PA-4
 - Indicator holder MH6-51 (☞ 24), Adapter A4-6 (☞ 34) or depth extension TV4 (☞ 37)
 - BMD-PA6
- Adapter A6-10-L-PA, otherwise as for BMD Series 6

Nominal diameter	Measuring pressure
3.0 - 4.2	0.8 - 1.0 N
4.2 - 9.5	1.0 - 1.5 N
9.5 - 20.5	1.2 - 1.8 N
20.5 - 30.0	1.5 - 2.0 N

BMD-PA4

Nom. diameter range: 3.0 – 4.9 mm

Gauging contacts: MCR, MHM (Type S to 4.0 only)

Guide cylinder: in OCR only

Types: S, FB

L1: BMD-PA4-S-MCR L1 = 1.4 mm

BMD-PA4-FB-MCR L1 = 0.5 mm

||Z = Nom. diameter -0,02 / -0,04

B = Nom. diameter + 1 mm

Measuring range: 0.25 mm

Sample order: BMD-PA-4-S-MCR-4.35

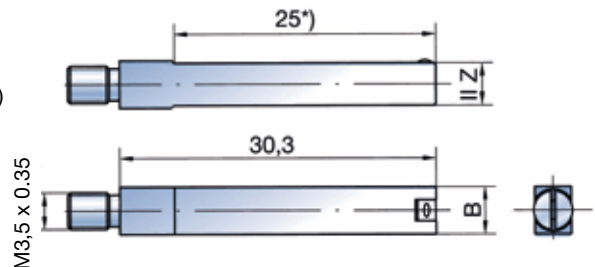

* Length 25 is available only for distances of less than 4 mm.

BMD-PA4

Nom. diameter range: > 4.9 – 9.5 mm

Gauging contacts: MCR, MHM (Type S only)

Guide cylinder: in OCR only

Types: S, FB

L1: BMD-PA4-S-MCR L1 = 1.8 mm

BMD-PA4-S-MHM L1 = 1.8 mm

BMD-PA4-FB-MCR L1 = 0.8 mm

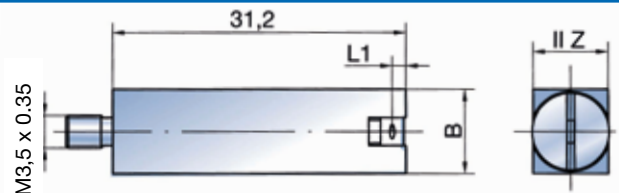

||Z = Nom. diameter -0,02/-0,04

B = Nom. diameter + 1 mm, Measuring range: 0.25 mm

Sample order: BMD-PA4-S-MHM-6.3

BMD-PA6

Nom. diameter range: > 9.5 – 30 mm

Gauging contacts: MCR, MHM

Guide cylinder: in OCR only

Types: S, FB

L1: BMD-PA6-S-MCR L1 = 3.5 mm

BMD-PA6-S-MHM L1 = 3.5 mm

BMD-PA6-FB-MCR L1 = 1.0 mm

BMD-PA6-FB-MHM L1 = 1.0 mm

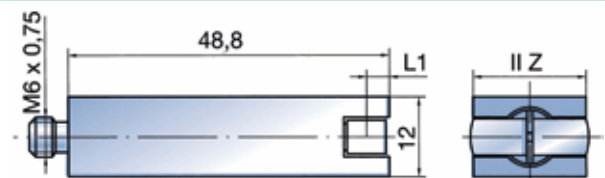

||Z = Nom. diameter -0,02/-0,05

B = 12.0 mm

Measuring range: 0,3 mm

Needle für BMD-PA4

Carbide needle (without groove) for BMD-PA4-S-MCR and BMD-PA4-S-MHM = Order Code NT-HM-PA1-150

Carbide needle (with 2 grooves) for BMD-PA4-FB-MCR = Order Code NT-FB-HM-PA1-150

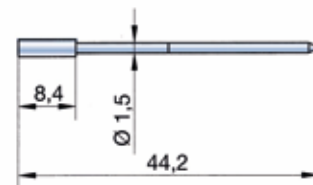

Needle für BMD-PA6

Carbide needle (with one groove) for BMD-PA6-S-MCR and BMD-PA6-MHM = Order Code NHM3-310

Carbide needle (with 2 grooves) for BMD-PA6-FB-MCR and BMD-PA6-MHM = Order Code NFB-HM3-310

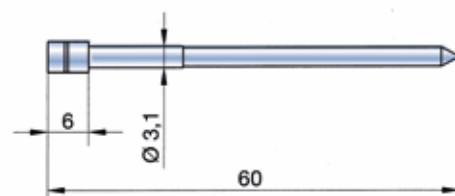

Multiplane plug gauges are capable of measuring up to 8 bore dimensions simultaneously. ME-BMD types are available for use in manual gauging (with entry groove) or for automatic bore gauging (with pilot taper PK). All multiplane plug gauges are special BMD gauges and are

configured for specific measurement applications. Therefore, your enquiry should include all workpiece data, such as:

- bore drawing or detail
- workpiece material
- position of measuring points

The most important currently available primary dimensions, distances and gauging contact

configurations are listed in the table below. Deviations are possible under certain conditions, however. Please ask!

Multiplane plug gauge characteristics:

- Gauging radius $R = 4.5 \text{ mm}$; with pilot taper (PK) $R = 2.5 \text{ mm}$
- Linearity and repeatable accuracy may deviate from the

standard (due to the asymmetrical configuration of the mechanical gauging elements).

- Hard chrome coated cylinder
- Steel cover $L = 1.0 \text{ mm}$
- Depth measuring possible on collar or bottom

BMD-ME

Primary dimensions

Specific dimensions, e.g. minimum length (6.5 mm) or minimum diameter, of the individual guide cylinders can be reduced under certain circumstances. The radial configuration of the gauging contacts is shown in the table below. Different connection types are listed in the table below.

Inquiries

In order to prepare an offer, we require a workpiece drawing with the following information:

1. Distance from gauging planes to a workpiece reference edge
2. Radial/angular position of gauging contacts – see table
3. Bore diameter, tolerance and the desired measuring range
4. Type of connection

Connection types

Depending on the specific application (manual gauging, installation in a gauging system, etc.), multiplane BMD can be fitted with different types of connections.

Connection threadings will also differ depending upon the number of gauging planes (see 23). The most commonly used connections are listed below.

Other connection dimensions and types are available on request. The type 5, size 2 connection is required for the BMD-ME plug gauge with floating holder for multiplane BMD gauges (SH-BMD-ME).

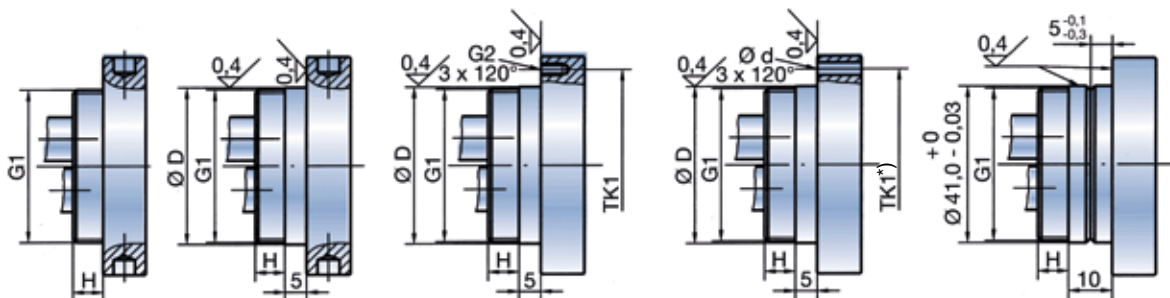
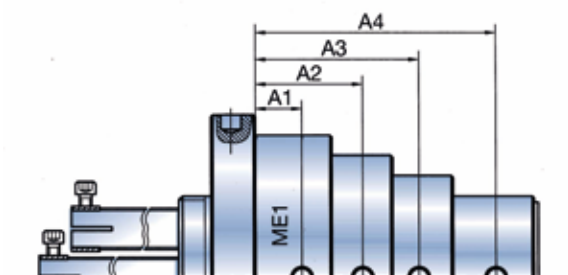
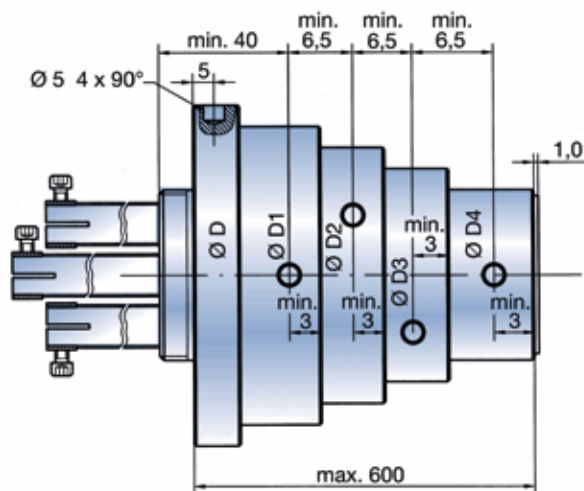

Type 1

Type 2

Type 3

Type 4

Type 5

*) will be defined on receipt of order

for connection size 1 and 2



Connection dimensions for multiplane BMD

Connection size	Thread (G1)	Thread height (H)	Ø D + 0/-0,03	Thread (G2)	Pitch diameter (TK1)
1	M35 x 1.5	7 mm	36 mm	M5	52 mm
2	M40 x 1.5	8 mm	41 mm	M5	57 mm
3	M52 x 1.5	10 mm	53 mm	M6	70 mm

The following table shows current available minimum guide cylinder diameters for the individual measurement planes.

Deviations from these dimensions are possible in specific cases.

Minimum diameters for multiplane BMD

Type	Min. possible cylinder Ø					Angular position of contacts in plug cylinder				Connection size
	Ø D	Ø D1	Ø D2	Ø D3	Ø D4	ME 1	ME 2	ME 3	ME 4	
BMD-1ME	37.5	15				0-180°				1
BMD-2ME-13-10	37.5	22	22			0-180°	0-180°			1
BMD-2ME-13-12	37.5	30	30			0-180°	0-180°			1
BMD-2ME-15-9	37.5	32	24			0-180°	0-180°			1
BMD-2ME-15-18	37.5	33	30			0-180°	90-270°			1
BMD-2ME-20-1	37.5	35	35			0-180°	90-270°			1
BMD-2ME-20-2	37.5	35				0-90-180-270°				1
BMD-3ME-13	37.5	21	21	21		0-180°	120-300°	60-240°		1
BMD-3ME-20	37.5	35	35	35		0-180°	120-300°	60-240°		1
BMD-3ME-0-24-1	46	46	39	8		0-180°	0-180°	0-180°		2
BMD-4ME-20-1	42.5	42	42	42	35	0-180°	0-180°	90-270°	90-270°	2
BMD-4ME-24-26-2	42.5	39	8			as desired f.e. 0-180°	0-180°			2
BMD-4ME-24-26-3	42.5	41	41	41	41	0-180°	90-270°	45-225°	135-315°	2
BMD-4ME-24-26-4	42.5	39				0-90-180-270°				2
BMD-4ME-24-26-5	42.5	41	41			0-90-180-270°		45-135-225-315°		2
BMD-4ME-24-26-6	42.5	41	41	41		0-90-180-270°		45-225°	135-315°	2
BMD-8ME-20-38	60	60	60	60	60	0-180°	0-180°	90-270°	90-270°	3

Type	Min. possible cylinder Ø				Angular position of contacts in plug cylinder				Connection size
	Ø D5	Ø D6	Ø D7	Ø D8	ME 5	ME 6	ME 7	ME 8	
BMD-8ME-20-38	60	60	60	53	45-225°	45-225°	135-315°	135-315°	3

BMD-ME

Insertion aids

Depending on the specific application, multiplane BMD are configured as follows:

- with entry groove for manual gauging (see 9)
- with pilot taper (30°) for automatic gauging (see 9)

It is not necessary to affix the entry groove/pilot taper to the first cylinder.

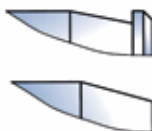

Clean stream nozzle

With separate air-hose fitting for compressed air supply at up to 10 bar for removal of coarse dirt deposits. The blower nozzle is supplied from an air chamber that is separated from the measurement system.

Please note:
The blower nozzle is not a substitute for a cleaning station. If the workpiece is heavily fouled, additional measures must be taken.

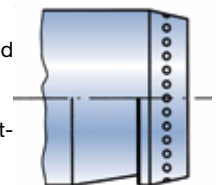

MH6 indicator holders are available in several different designs. They are used for Series 6 BMD and along with adapters (34, 35) for series 4 plug gauges (threading M3.5 x 0.35)

MH6-51

Standard indicator holder for Series 6 BMD, without transfer pin

With clamping fixture

Clamping bore	Order Code
8H7	MH6-51
3/8"H7	MH6-51-Z

Core of holder hard-chrome plated

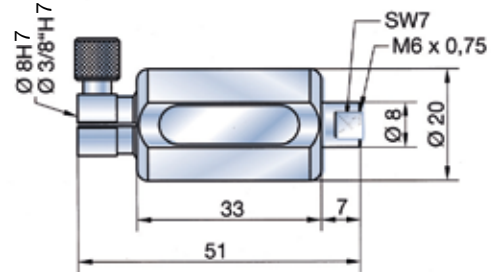

MH6-73-R

Indicator holder with pin retraction

When the button (1) is pressed, the indicator gauging pin is retracted from the BMD pressure needle, removing gauging pressure from the gauge. See also Type "PG", 8

With clamping fixture

Clamping bore	Order Code
8H7	MH6-73-R
3/8"H7	MH6-73-R-Z

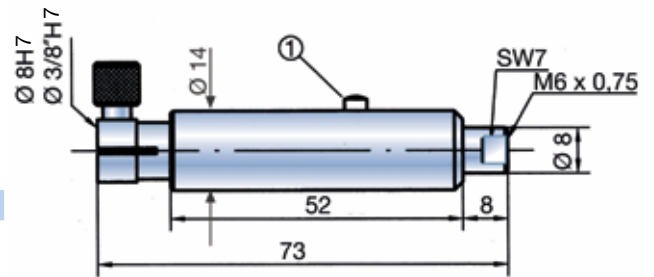

MH6-

Indicator holder for Series 6 BMD, temperature stabilized

The holder is ordinarily equipped with two marking strips.

Type

Clamping bore	Order Code	Length L	Length A
8H7	MH6-150	150 mm	25 mm
8H7	MH6-200	200 mm	75 mm
8H7	MH6-300	300 mm	175 mm
3/8"H7	MH6-150-Z	150 mm	25 mm

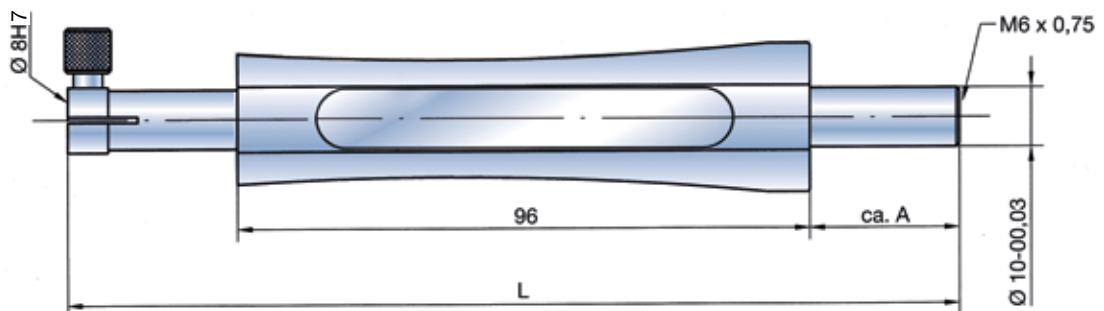

MH10 indicator holders are available in several different designs. They are used with Series 10 plug gauges.

When fitted with an adaptor (see 24, 35, the holders can also be used with Series 6 (M6 x 0.75 threading) and Series 4 (M3.5 x 0.35 threading) BMD.

MH10-61

Standard indicator holder for Series 10 BMD, without transfer pin

With clamping fixture

Clamping bore	Order Code
8H7	MH10-61
3/8"H7	MH10-61-Z

Core of holder hard-chrome plated

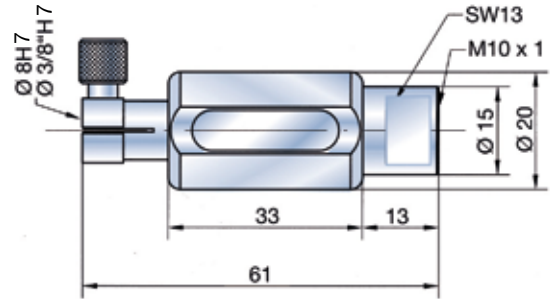

MH10-150

Indicator holder, temperature stabilized

With clamping fixture

Clamping bore	Order Code
8H7	MH10-150
3/8"H7	MH10-150-Z

The new MH10-150 is supplied with 2 marking strips as standard (BL). The impact protection (see MH10-150-P, 26) can be easily fit: The clamping screw is replaced with an Allan screw. The impact protection is simply affixed and clamped with 2 screws.

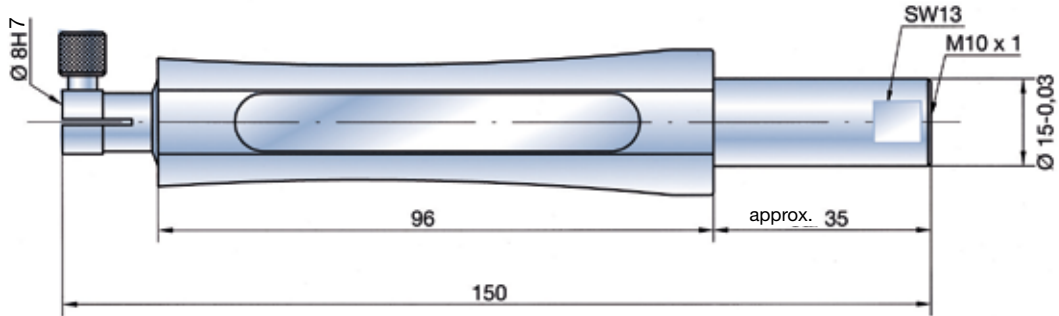

MH10-150-R

Indicator holder, temperature stabilized, with retraction

All dimensions same as for MH10-150, with additional button. By pressing the push button (1) the indicator measuring pin is retracted from the pressure needle of the BMD. The measuring pressure is now removed from the BMD. See also type "PG", (8).
Type MH10-150-R-P with impact protection.

With clamping fixture

Clamping bore	L	Order Code
8H7	35	MH10-150-R
8H7	25	MH10-150-R-P
3/8"H7	35	MH10-150-R-Z
3/8"H7	25	MH10-150-R-P-Z

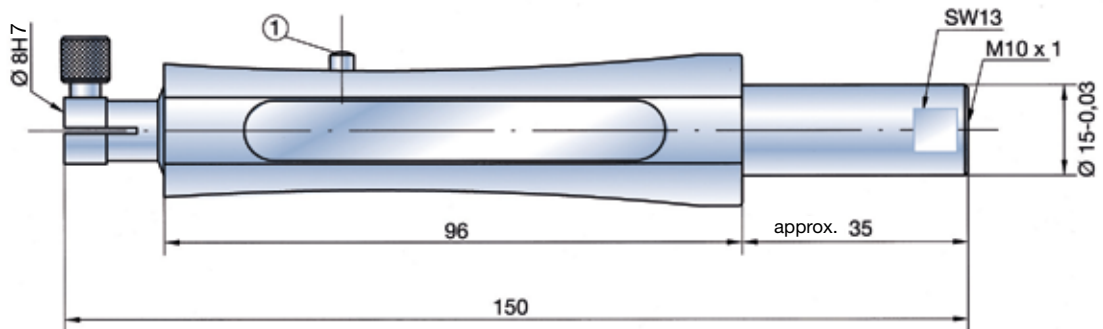

- DIATRON1000-V10
- DIATRON1000-V6
- DIATRON1000-V4

Indicator holder with integrated precision display

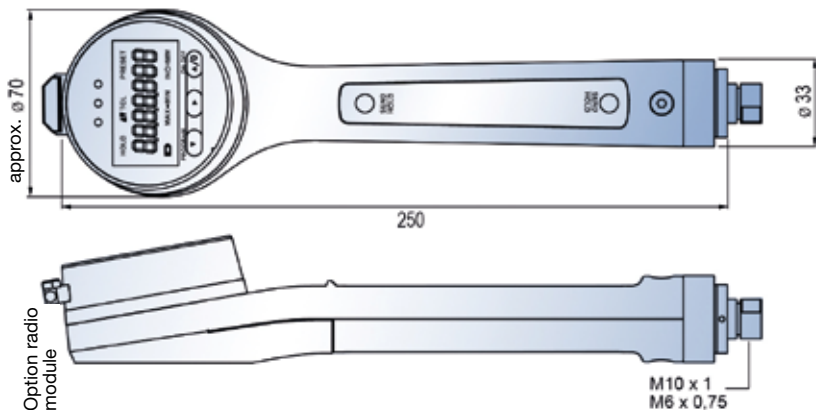

- Complete system with display of 7-digit display
- High data security by radio transmission
- Resolution 0.0001mm (0.000005 inch)
- Travel: 3 mm
- ±0.0002 mm linearity deviation over 3 mm travel
- Switch mm/inch
- Password protection
- Programmable at the measuring instrument
- Static or dynamic measurement possible
- Display of tolerances can be used in all measuring modes
- Transfer of measured values to RS232 or USB-interface
- With fine adjustment
- Splashproof
- For very small tolerances, please use option MZ for BMD

Radio transmission as an option

- Up to 120 devices per one receiver
- Operating distance up to 200 m (depending on environment)
- Free software for data reception

MH10-P

MH6-P

Indicator holder with impact shroud protection

Temperature-stabilized holder for indicators MDU125, MU10M, MU1M and F1000 (indicator not included in price). The holder is supplied with 2 marking strips. The impact protection can be removed simply by loosening the two clamping screws (see also MH10-150, 25).

Types

With clamping 8 mm	With clamping 3/8"
MH10-150-P	MH10-150-P-Z
MH10-61-P	MH10-61-P-Z
MH6-150-P	MH6-150-P-Z
MH6-51-P	MH6-51-P-Z

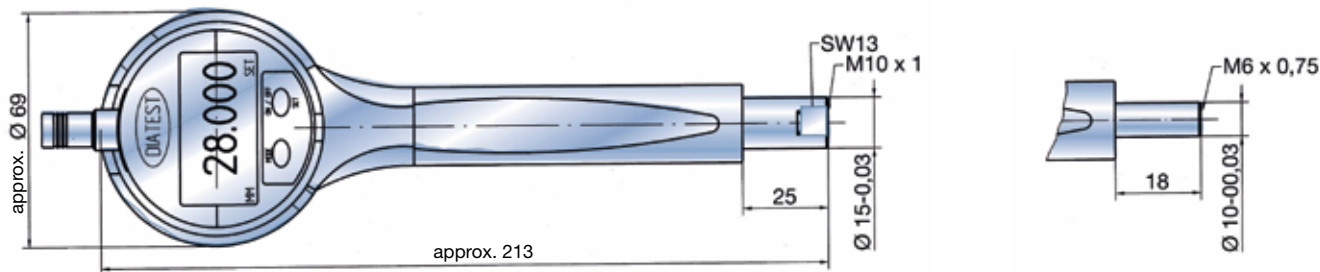

BL

Marking strip BL (extra charge)

A large number of holders are equipped with marking strips as standard (see table). The dimensions indicated below apply to all marking strips except for holder MH10-150-F. A second marking strip can be affixed to several types of holders (e.g. EH, AH, EH-M). Holders which ordinarily do not have marking strips can be equipped with these, if requested. Please enquire.

Order suffix: 1st strip BL-1
2nd strip BL-2

Replacement marking strips for holders (except MH10-150-F)

Order Code BLE

Holder	No. of BL	Page
MH6-51	1	24
MH10-61	1	25
MH6...	2	24
MH10-150 (R-P)	2	25/26
L-MH10-150	2	30
MH10-150-R	2	25
EH-V	2	30
EH-V-DS	1	30
MH10-150-F	1	30
MH10-150-P	2	26
MH10-170-D	2	32
MH10-150-PG	2	32
AH6/10-61	1	33
AH6/10-140	1	33
DIATRON1000	1	26
EH-M	1	31

Function and installation

The complete spring unit with M2.5 threading is installed in place of the indicator stem. The unit is regulated by adjusting the spring nut. The correct gauging pressure setting must be determined by trial and error. The basic approach is to determine the lowest gauging pressure at which acceptable repetition

accuracy is ensured. Please note: The measuring pressure has to be adjusted in the same position as measurements will be taken later in the workpiece (either horizontal or vertical). The knurled sleeve on holder MH4-67-F provides excellent protection from breakage for

Series 4 BMD. It also serves as a continuously adjustable depth stop (0 – 20 mm). The holder can also be clamped directly into the clamping fixture, as the protective sleeve has a diameter of 15 – 0.03 mm.

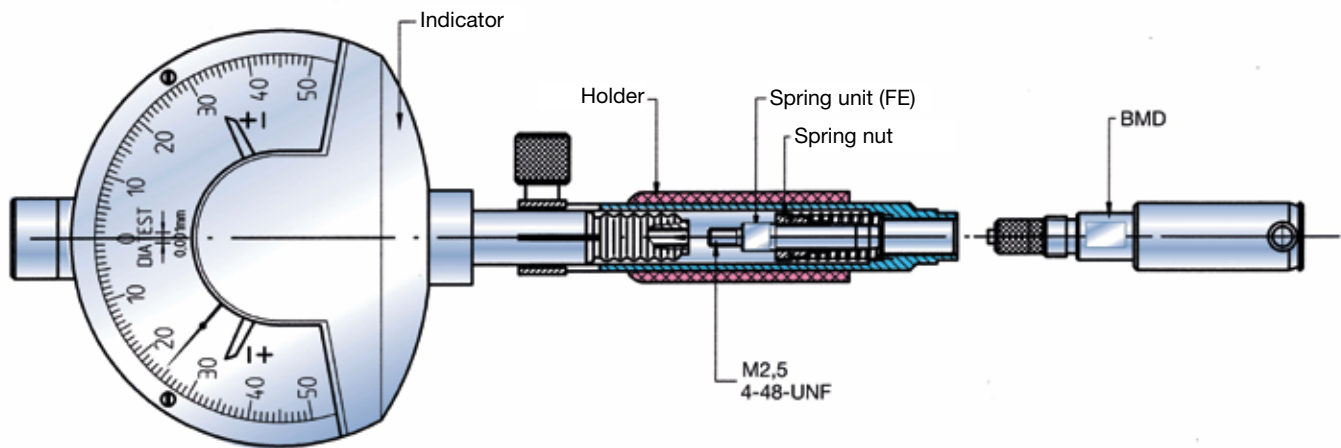

Procedure

1. Replace the stem of the indicator with the complete spring unit.
2. Screw the BMD into the holder and tighten.
3. Set the required counter-pressure (against the indicator) by adjusting the spring nut.
4. Clamp the indicator unit into the holder.
5. Test gauging pressure and repeat step 3 as needed.

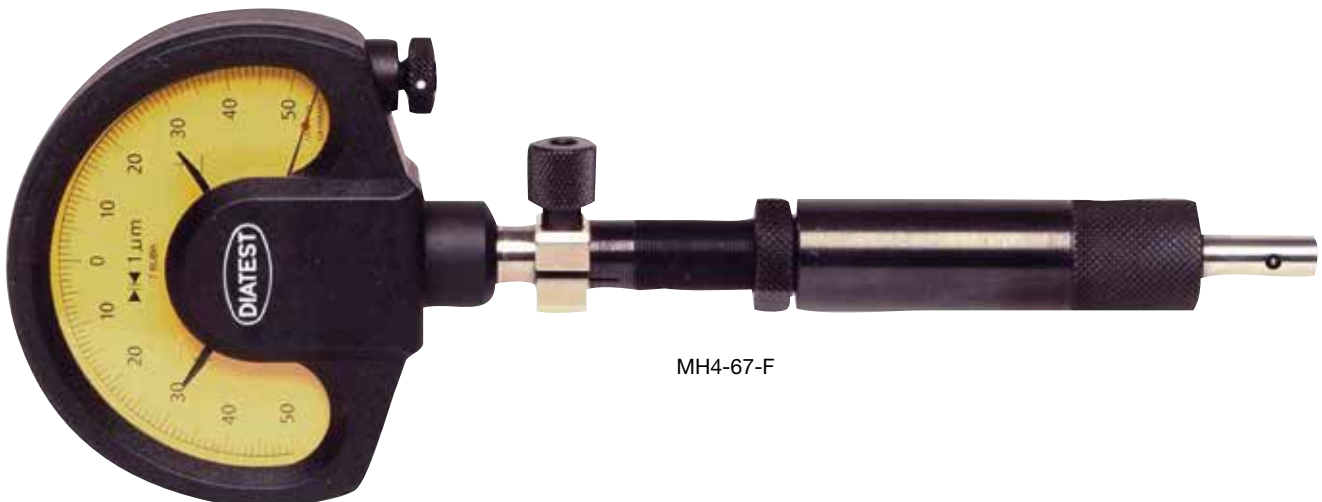

MH4-67-F

Holders with adjustable spring pressure should be used whenever no indicator with the appropriate measuring pressure is available (see 6) or when minimum measuring pressure is required for technical reasons (e.g. very thin walled workpiece).

MH4-67-F

Indicator holders with adjustable spring pressure for Series 4 BMD

The knurled sleeve (1) protects the BMD and can also be used as a depth stop.

When ordering without BMD please indicate $\varnothing D$!

With clamping fixture:

Clamping bore	Order Code
8H7	MH4-67-F
3/8"H7	MH4-67-F-Z

Separate knurled sleeve:

for	Order Code
MH4-67-F	MH4-67-F-RH
MH4-67-F-Z	MH4-67-F-RH-Z

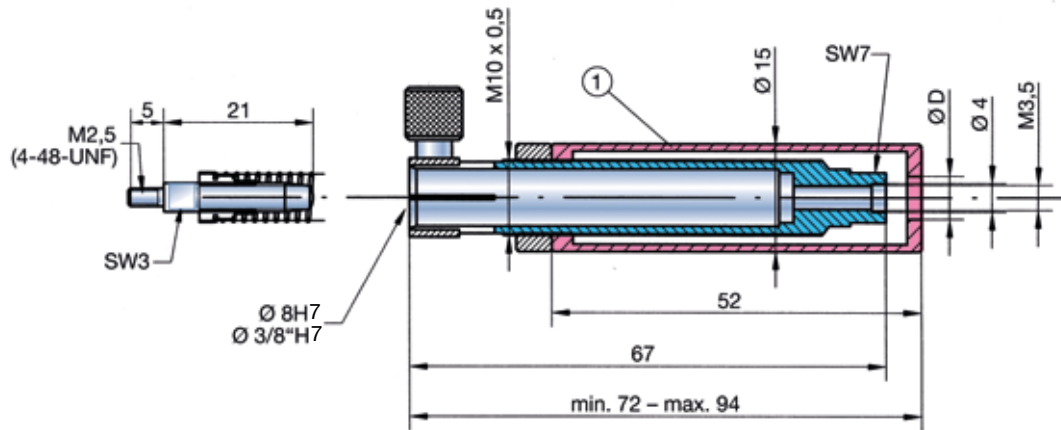

MH6-65-F

Indicator holders with adjustable spring pressure for Series 6 BMD

With clamping fixture:

Clamping bore	Order Code
8H7	MH6-65-F
3/8"H7	MH6-65-F-Z

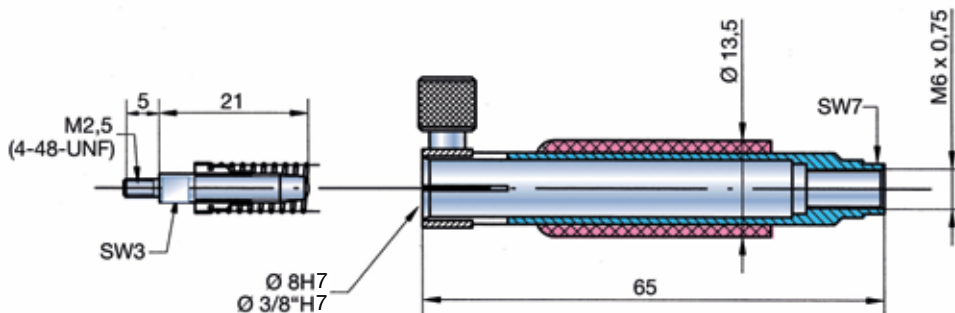

Holder configuration and installation

The clamping unit (8) is available in $\text{Ø} 8\text{H7}$ or in $3/8\text{H7}$. The probe (7) with maximum $\text{Ø} 12\text{ mm}$ and a maximum length of 140 mm is mounted into holder and protected against shocks.

Once probe is installed and cable

clamped into cable guides (2), probe cable is protected against excessive cable bending by bend protection (1). Fine adjustment (11) by counter nut (10) can be performed to adjust probe and BMD probe.

This allows to position the probe always at the electrical zero point. Holders are equipped with 2 marking strips as standard (version EH-V). One marking strip can be replaced by a membrane keyboard as an option

(version EH-V-DS). This version allows to send measured values by pressing a button.

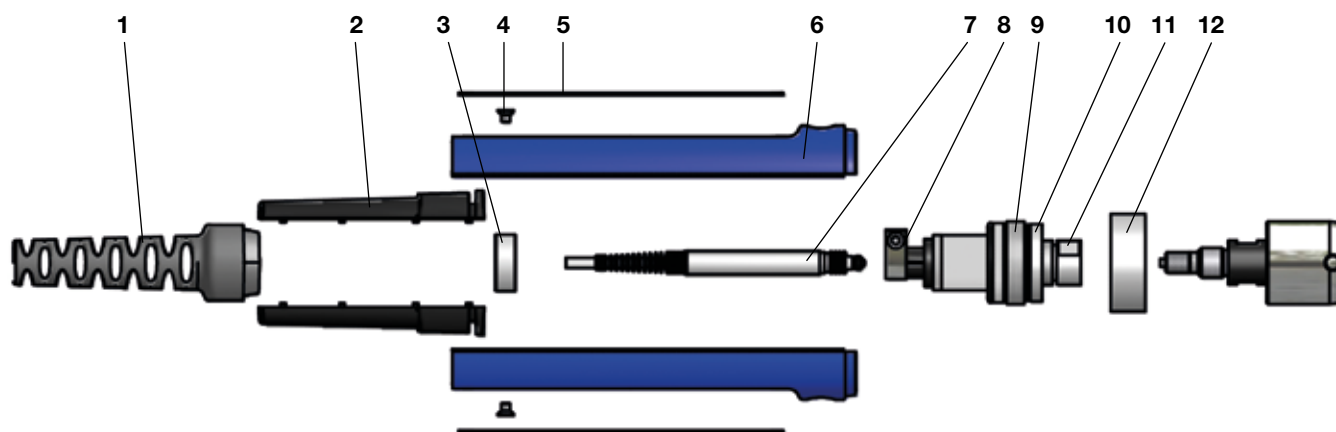

1. bend protection
2. cable guide
3. connecting ring

4. screws
5. marking strips
6. grip plates

7. probe
8. clamping unit
9. holder unit

10. counter nut
11. fine adjustment
12. retaining ring

Extension and installation for deep bore measurement

The extension is ideal for applications requiring measurement of deep bores in combination with electrical probes. When using a TVT15, it is important to ensure sufficient probe cable length, as a combination with an extension cable inside the TVT15 is not possible.

The probe (2) is inserted through the depth extension TVT (4) and clamped in the holder EH10-61 (1). A cable clamp TVT-EHK (5) can be used as a cap (does not apply when using an extension cord, as the probe plug cannot be drawn through the cap).

In order to prevent jamming of the BMD in the bore, it is advisable to use clampable support rings (3) – available on request. For extensions and cable clamping fixtures see 39.

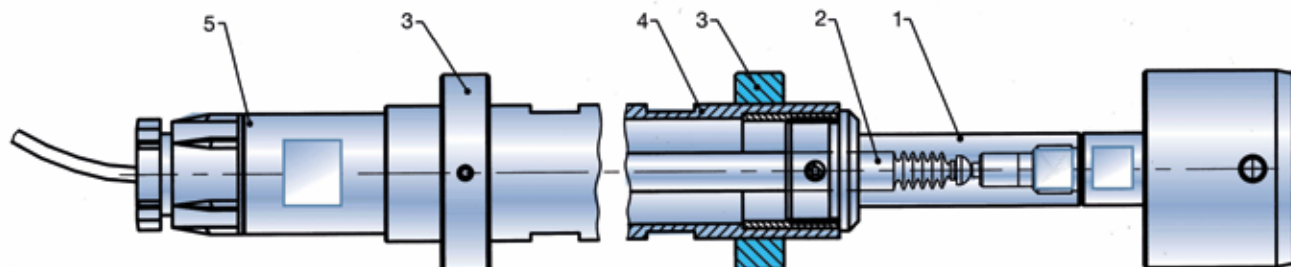

1. Holder EH10-61-T15
EH10-61-T28

2. Probe

3. Support rings

4. TVT- 39)

5. TVT-EHK 39)

Electrical holders are used to mount transducers connected to other units, e.g. Diatron 6000, Diatron 2200 or a computer.

EH-V

Electrical holder with fine adjustment M6 x 0,75 or M10 x 1 threading

Holder for transducers. The electrical zero point of transducer can be adjusted without moving it by using the external fine adjustment.

Available with suspension as an option.

Clamping bore	Connection threading	Order Code
8H7	M3.5 x 0.35	EH-V4
8H7	M6 x 0,75	EH-V6
8H7	M10 x 1	EH-V10
3/8"H7	M3.5 x 0.35	EH-V4
3/8"H7	M6 x 0,75	EH-V6-Z
3/8"H7	M10 x 1	EH-V10-Z

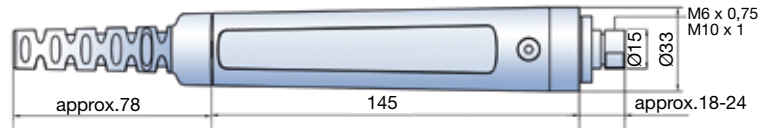

EH-V-DS

Electrical holder with push buttons M6 x 0,75 or M10 x 1 threading

Type of holder with 2 push buttons for storage of measured values. One marking strip and one membrane keyboard are mounted instead of 2 marking strips. A cable can be layed on the open end of the membrane keyboard by a zero-force connector allowing a link to a peripheral device.

The requested function can be activated by pressing a button (i.e. to send the measured result). Both of the buttons are parallel-connected.

Clamping bore	Connection threading	Order Code
8H7	M3.5 x 0.35	EH-V4-DS
8H7	M6 x 0.75	EH-V6-DS
8H7	M10 x 1	EH-V10-DS
3/8" H7	M3.5 x 0.35	EH-V4-DS-Z
3/8"H7	M6 x 0.75	EH-V6-DS-Z
3/8"H7	M10 x 1	EH-V10-DS-Z



MH Spezial-Messuhrhalter

MH10-150-F

Indicator holder with adjustable spring pressure

Gauging pressure of indicator can be adjusted by approx. ± 1 N by adjusting and locking the two grip sleeves (1 and 2) on the holder.

This is especially important for measuring of thin-walled workpieces and in order to reduce wear on the BMD contact points. The holder is ordinarily equipped with 1 marking strip.

With clamping fixture:

Clamping bore	Order Code
8H7	MH10-150-F
3/8"H7	MH10-150-F-Z

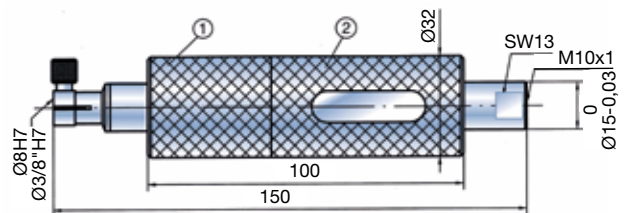

L-MH10-150

Indicator holder, temperature stabilized, for BMD with air supply

For air hoses with an inside diameter of 3.0 mm and an outside diameter of 4.3 mm. Required air pressure: 2-3 bar. The holders are equipped with two marking strips as standard.

With clamping fixture:

Clamping bore	Order Code
8H7	L-MH10-150
3/8"H7	L-MH10-150-Z

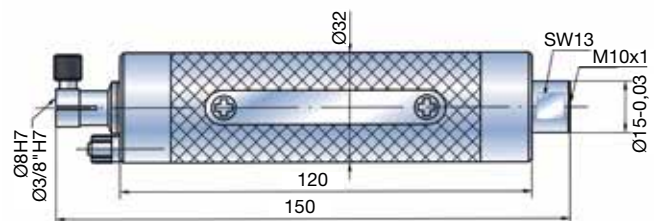

EH10-61-T15

Probe holder for TVT15

This holder is suitable only for electrical probes with $\varnothing 8H7$ clamping fixtures in combination with DIATEST depth extension TVT15.

Characteristics as for EH10-61-T28.

However, no extension cables can be used inside the TVT15.

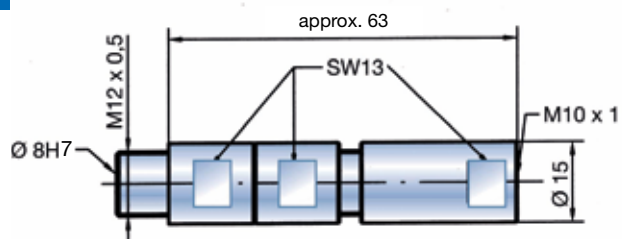

EH10-61-T28

Probe holder for TVT28

This holder is suitable only for electrical probes with $\varnothing 8H7$ clamping fixtures in combination with DIATEST depth extension TVT28.

Advantage: The measurement is made by the probe on BMD itself, without influence of additional mechanical components between gauge and probe. This makes it possible to perform measurements at depths of several metres with maximum precision. Inside diameter of TVT28 is large enough to allow for connection of a probe plug and an extension cable.

Minimum bore diameter: 28.5 mm.

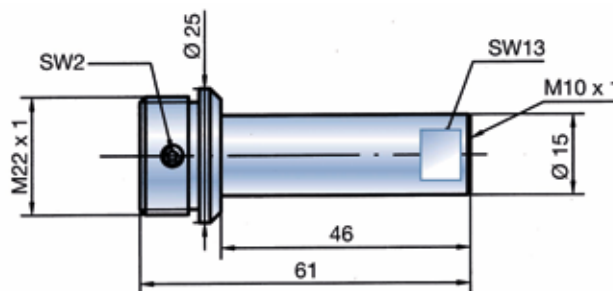

EH10-S

EH6-S

Holder for wireless measuring probe FMTD with radio module FMTD-S

The wireless measuring probe with wireless module can be securely mounted in the holder. The plastic handle prevents the radio module from being shielded.

Connecting thread	$\varnothing D$	L
M10x1	15 mm	176 mm
M6x0.75	8 mm	170 mm

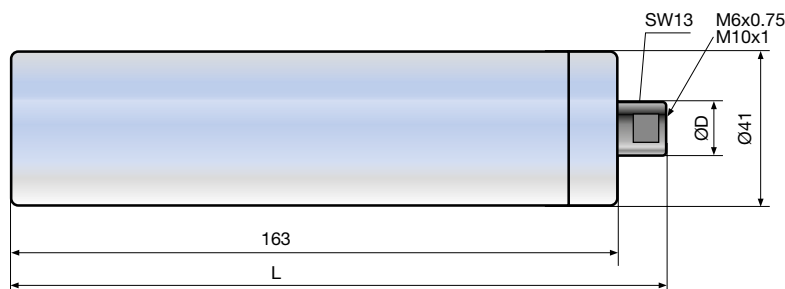

EH-M

Electrical holders for multiplane plug gauges

These holders are equipped with one marking strip as standard (see 22). Consult the table on 23 for the appropriate model (connecting thread).

These holders are equipped with one marking strip as standard.

Model	Connection size	Threading G	$\varnothing D$
EH-M35 x 1.5	1	M35 x 1.5	38 mm
EH-M40 x 1.5	2	M40 x 1.5	42.5 mm
EH-M52 x 1.5	3	M52 x 1.5	56 mm

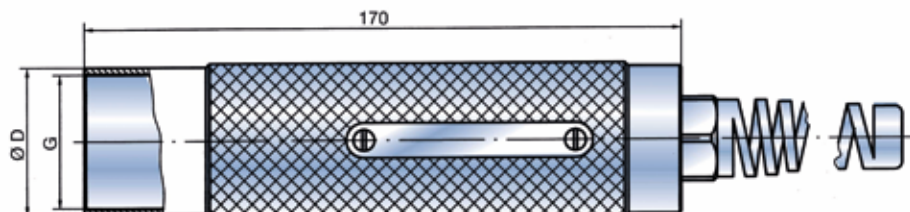

MH10-170-D

Indicator holder with rotating dial

This indicator holder allows 360° rotation of the BMD in the workpiece. The measured value display remains stationary and easy to read. This holder is ideal for testing for oval or polygonal deformation.

The holder is supplied with two marking strips as standard.

With clamping fixture:

Clamping bore	Order Code
8H7	MH10-170-D
3/8"H7	MH10-170-D-Z

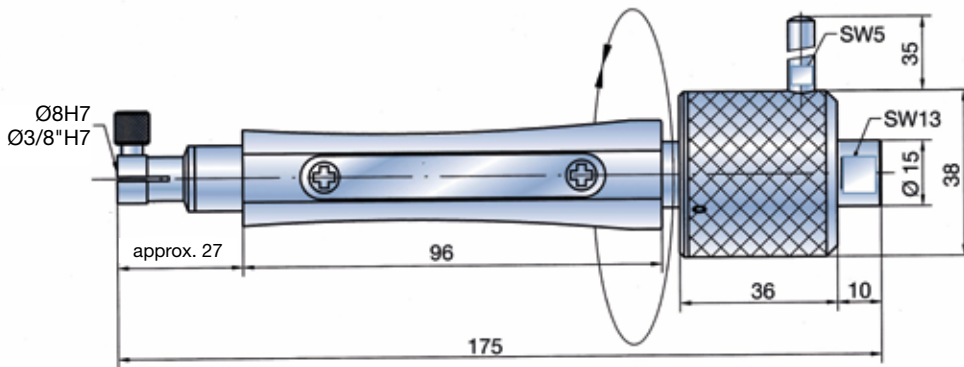

MH10-150-PG

Indicator holder with gauging pressure retraction

Indicator gauging pressure is removed using a bolt (1). BMD type PG (see 8) can be inserted into the bore without contact pressure (helps to reduce wear, particularly advantageous with sensitive surfaces, etc.)

With clamping fixture:

Clamping bore	Order Code
8H7	MH10-150-PG
3/8"H7	MH10-150-PG-Z

The holder is supplied with two marking strips as standard.

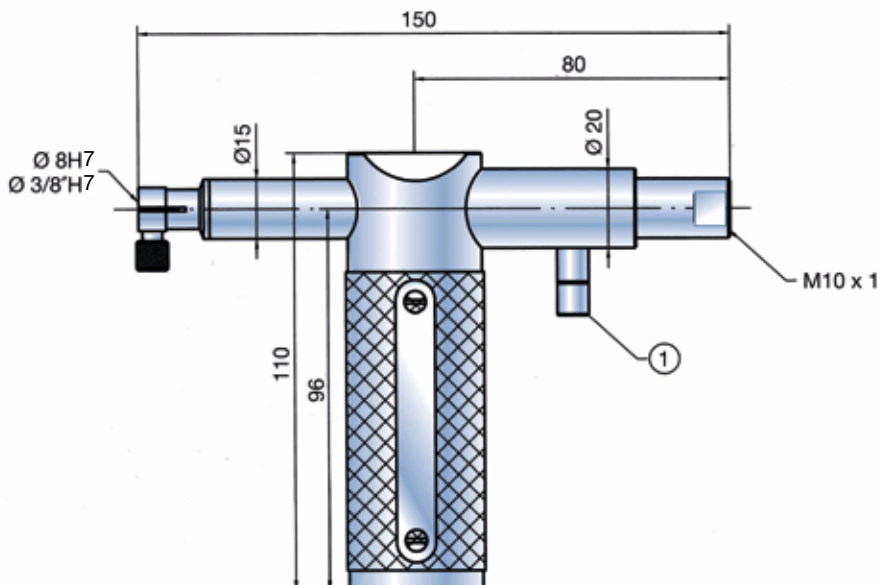

Special holders are available for ANA indicators (ANA1 and ANA-RS232). The indicator is fixed firmly in the holder by a dual-tangent clamp.

Shifts in the position of the indicator are virtually impossible, even under heavy load conditions. If different measurement indicators are used, the dimension of 41 mm must be maintained. The holders are supplied with one marking strip as standard.

It is practically impossible to shift the display accidentally with analog holders. Adjustments are performed using the fine adjustment inside the holder. Fine adjustment is secured by tightening the SW3 Allan screw (1). The adjustment range is approximately ± 1 mm.

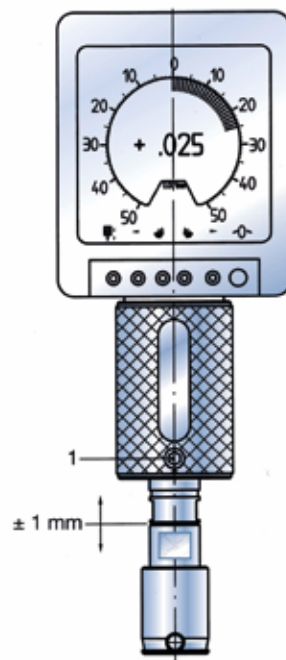
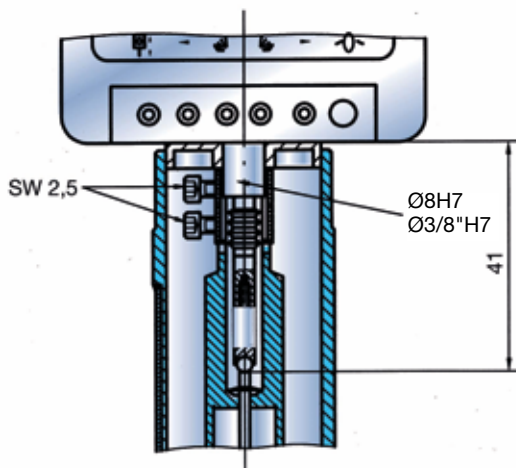

AH6-61

AH10-61

Short holder for the Analog indicator

Indicator holder without transfer pin

Model	Clamping bore	Connection thread
AH6-61	Ø 8H7	M6 x 0,75
AH6-61-Z	Ø 3/8"H7	M6 x 0,75
AH10-61	Ø 8H7	M10 x 1
AH10-61-Z	Ø 3/8"H7	M10 x 1

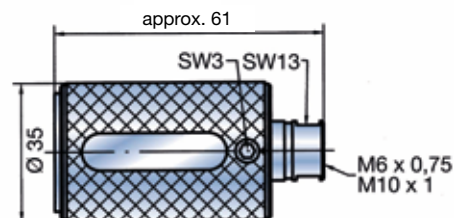

AH6-140

AH10-140

Holder for Analog indicator

Indicator with transfer pin

Model	Clamping bore	Connection thread
AH6-140	Ø 8H7	M6 x 0,75
AH6-140-Z	Ø 3/8"H7	M6 x 0,75
AH10-140	Ø 8H7	M10 x 1
AH10-140-Z	Ø 3/8"H7	M10 x 1

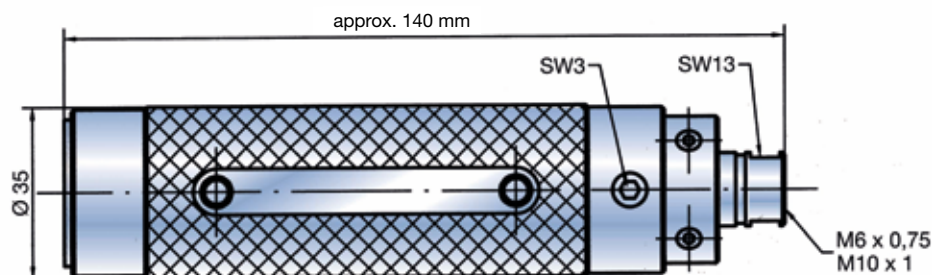

BMD adapters are used to connect BMD gauges with smaller threads to BMD accessories with larger threads.

Model SP: With protective bore (fracture protection for the plug gauge). Dimension X = distance between plane surface of plug thread and the adapter threads.

In addition to the adapters, depth extensions TV4 and TV3,8 (see 37) also function as adapters.

Please note: When using adapters, it is important to ensure sufficient indicator pressure, especially with adapters for BMD series 4

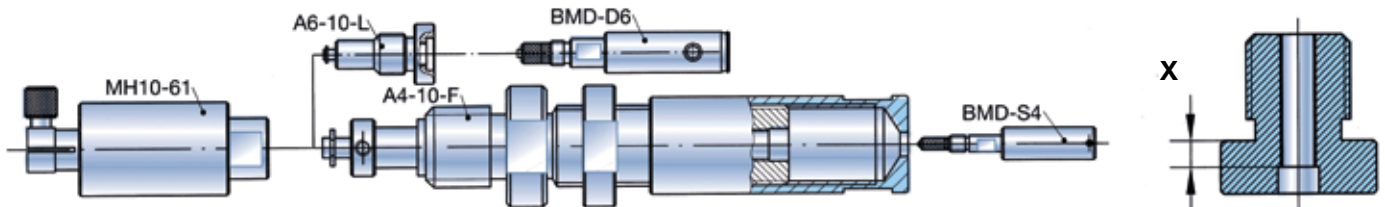

Adapters for Series 4 BMD

A4-6

Series 4 to Series 6 adapter

The adapter is designed to be used for BMD-PA as well.

X = 1

Adapter with supplementary fracture protection available
Order Code A4-6-SP

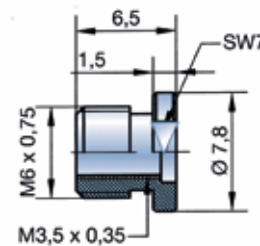

A4-10

Series 4 to Series 10 adapter

Please note: This adapter is not suitable for use with series 10 accessories with transfer pins (e.g. TV15 or MH10-150).

X = 3

Order Code A4-10

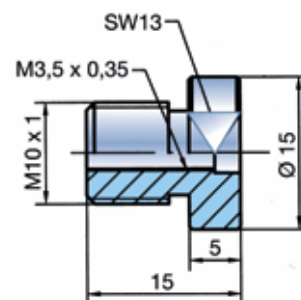

A4-10-F

Series 4 to Series 10 adapter with adjustable spring pressure

Series 4 BMD require a measuring pressure of 0.3 – 0.4 N. A spring in the adapter (1) counteracts the indicator gauging pressure. Spring pressure can be flexibly adjusted by turning sleeve B toward threaded pin A. The sleeve (3) serves as fracture protection and as a depth stop. It can be adjusted continuously from 0 to 20.5 mm. The sleeve is secured with the lock nut (2). For instruction on correct adjustment of minimum gauging pressure see 27.

Please indicate dimension Ø D in orders.

Example: A4-10-F-D=7.2

Order Code for separate sleeve (3): A4-10-F-RH

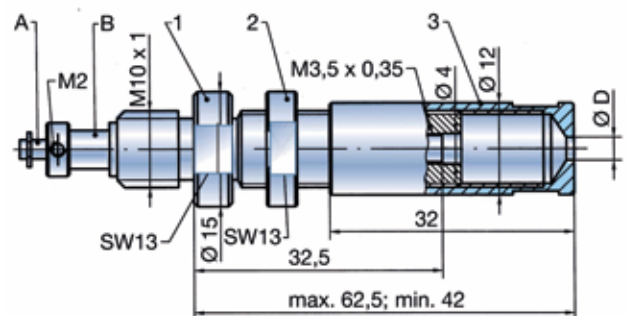

Adapters for BMD series 6

A6-10-L

Series 6 to series 10 adapter with transfer pin

This adapter is generally recommended for adapting from Series 6 to Series 10:

- The transfer pin permits the use of all series 10 accessories.
- BMD series L

Select model A6-10-L-PA for use with BMD-PA (not shown in illustration).

X = 3

Adapter with supplementary fracture protection available
Order Code A6-10-L-SP

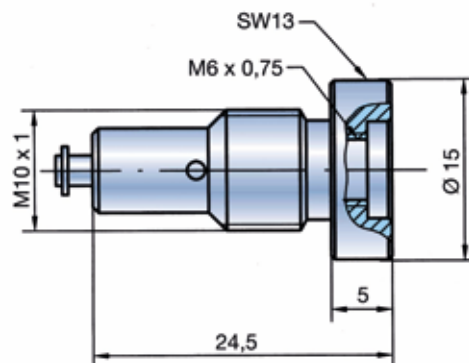

A6-10-0

Series 6 to Series 10 adapter

Please note: This adapter is not suitable for use with Series 10 accessories with pressure pins (for instance TV15 or MH10-150).

X = 3

Adapter with supplementary fracture protection available
Order Code A6-10-0-SP

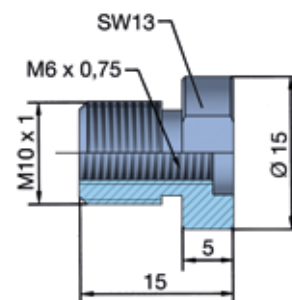

A6-6-F

Adapter for series 6 BMD with adjustable spring pressure

The spring pressure can be adjusted flexibly by turning the sleeve (1).

The sleeve is secured with the lock nut (2). For instruction on correct adjustment of minimum gauging pressure see 27.

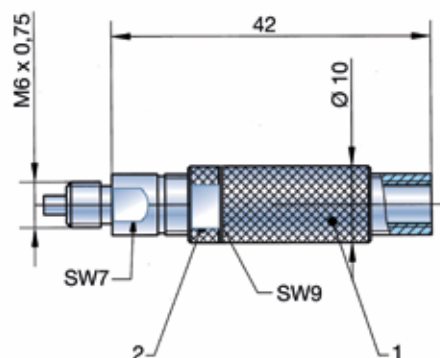

Right-angle attachments are used when working in confined spaces or for measuring lateral bores. The 90° diversion is effected with the aid of a high-precision transfer lever (2). When screwing in the BMD, it is important to ensure that the transfer lever is set in the lower position (see sketch).

The angular alignment of the plug gauge contacts (4) with the right-angle attachment (1) is not specified. If a specific angular position is preferred please specify when ordering.

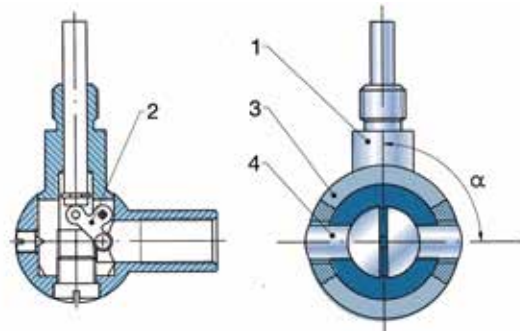

W6

Right-angle attachment for BMD series 6

An adapter is required for use with BMD series 4.
Order Code W6

Other right angle attachments with angle 45° and 60° also available (similar version)

Order Code 45°: W6-45

Order Code 60°: W6-60

Order Code 90°: W6

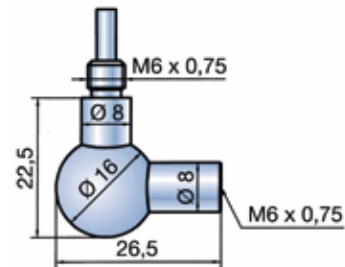

SO-W6

BMD with special right-angle attachment for BMD series 6

If the dimensions of the BMD with right-angle attachments are too long, model SO-W6 can be used as an alternative. In this version, the right-angle attachment and the BMD are shortened in the area of the thread connection. The BMD and the right-angle attachment form a single unit and can be ordered as a complete set only.

Please note: Dimension L1 of the BMD has to be added to the length of 51 mm!

Sample order: BMD-S6-CR-10-SO-W6

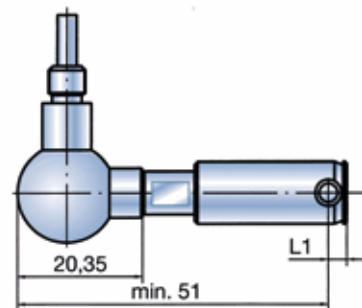

W10

Right-angle attachment for Series 10 BMD

Right-angle attachment L-W10 has to be used with plug gauges with air supply. Order Code W10 (BMD without air supply), L-W10 (BMD with air supply).

Other right angle attachments with angle 45° and 60° also available (similar version)

Order Code 45°: W10-45

Order Code 60°: W10-60

Order Code 90°: W10

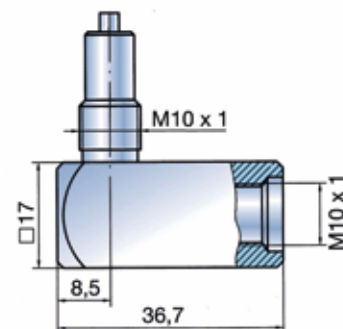

SO-W10

BMD with special right-angle attachment for Series 10

Use as described for SO-W6. A shorter version than the minimum length of 60 mm can be achieved by using BMD Series 6 BMD with SO-W6.

Please note: Dimension L1 of the BMD has to be added to the length of 60 mm!

Sample order: BMD-S10-CR-28-SO-W10

Also available in model L-SO-W10 (BMD with air supply)

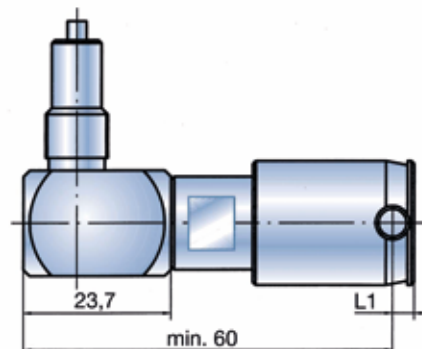

Two different types of depth extensions are available:

- Depth extension with transfer pin (TV)
- Depth extension without transfer pin (TVT)

TV depth extensions can be used for measuring depths of up to several meters, depending on the model.

Most of the depth extensions are temperature stabilized.

This means that temperature fluctuations, e.g. resulting from hand warmth, do not have a noticeable effect on the measuring results. It is important to ensure that the depth extension may not bend during the measuring process, as this will result in measuring errors. Only size TV8 (7, 8) and larger depth extensions are used in combination.

The TV4 extension has 2 different connection threadings (adapter function).

Depth extensions TV4 through TV15 are also available with additional pressure springs. This feature may be useful where a BMD with a longer extension is used in overhead work (the weight of the pressure pin counteracts the gauging pressure of the indicator) requiring increased total gauging pressure.

The spring can also be installed separately. Order suffix: F e.g. TV15-500-F

Type TVT depth extensions are suitable for use with probes only. The probe is clamped directly to the BMD using EH10-61-T28 (15) holders. The power cable is fed through the extension (39).

TV4 (3,8)

Series 4 depth extensions

TV4 depth extensions are designed for use with BMD series 4. These depth extensions cannot be used in combination. They are equipped with two different threads and thus also function as adapters (Series 4 to Series 6).

All series 4 depth extensions are temperature stabilized.

The TV4 is suitable for automatic measurement only under certain conditions.

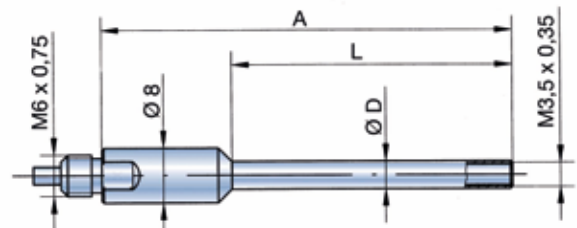

Ø D	L	A	Order Code
3.8	64	79	TV3.8-64
4.0	25	40	TV4-25
4.0	35	50	TV4-35
4.0	50	65	TV4-50
4.0	64	79	TV4-64

Ø D	L	A	Order Code
4.0	80	95	TV4-80
4.0	100	115	TV4-100
4.0	125	140	TV4-125
4.0	250	275	TV4-250
4.0	500	525	TV4-500
4.0	750	775	TV4-750
4.0	1000	1025	TV4-1000

TV8 (7,8)

Series 6 depth extensions

TV extensions with L = 80 and above are temperature stabilized. Multiple extensions can be used in combination.

Select model L-TV8 for use with BMD with air supply. The same dimensions apply: Example L-TV8-64

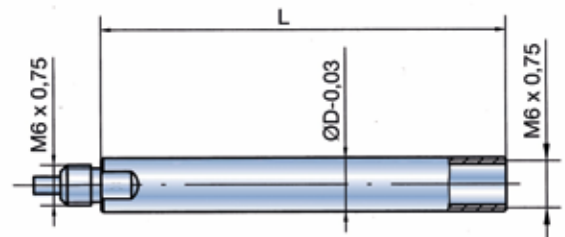

Ø D	L	Order Code
7.8	20	TV7.8-20
7.8	30	TV7.8-30
7.8	40	TV7.8-40
7.8	50	TV7.8-50
7.8	64	TV7.8-64

Ø D	L	Order Code
8.0	20	TV8-20
8.0	30	TV8-30
8.0	40	TV8-40
8.0	50	TV8-50
8.0	64	TV8-64
8.0	64	TV8-64-CR
8.0	64	TV8-h5-64
8.0	80	TV8-80

Ø D	L	Order Code
8.0	100	TV8-100
8.0	125	TV8-125
8.0	250	TV8-250
8.0	500	TV8-500



TV15

Series 10 depth extensions

These depth extensions are temperature stabilized. Multiple extensions can be used in combination.

With air supply:

The TV15 for BMD with air supply is available in 2 versions:

- 1 with lateral air connection for hose internal $\varnothing 3,0$
Order Code L-TVA15
- 2 with air connection in threading
Order Code L-TV15

L	Order Code	L	Order Code
45	TV15-45	125	TV15-125
64	TV15-64	250	TV15-250
80	TV15-80	500	TV15-500
100	TV15-100		

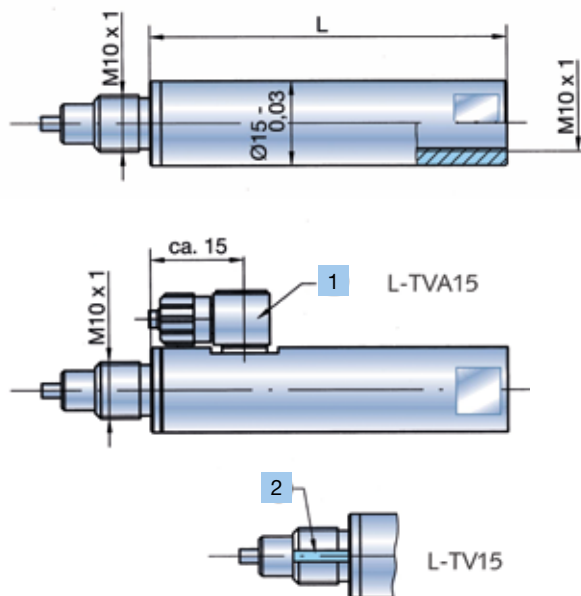

TV64-D

Rotary adapter for series 6

The rotary adapter enables the BMD to rotate by 360° in the bore. The measured value display remains fixed in place.

Application:
bore roundness testing.

L	Order Code
36	TV36-D
64	TV64-D

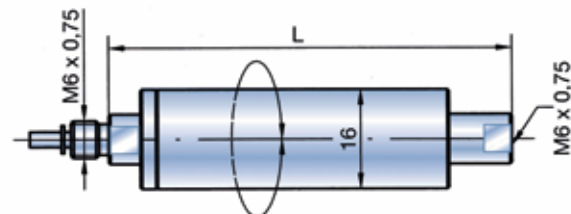

TV15-70-D

Rotary adapter for series 10

Same principle as TV64-D.
With M10 x 1 connection thread.

Longer size on request.

Order Code TV15-70-D

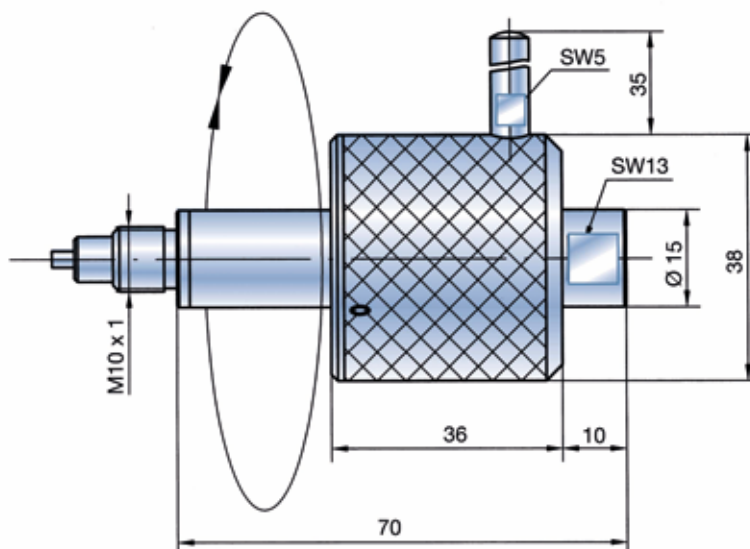

For measuring deep bores in combination with electronic probes (3) and correspondingly long cables or extensions. We recommend the use of support rings (4) to facilitate

insertion into the workpiece. These rings should be approx. 0.2 to 0.5 mm smaller than the workpiece bore. The probe is clamped into the EH10-61T holder (2) (see 107).

The probe cable runs through the depth extension (5) and is clamped in the TVT-EHK cable clamping fixture (6). The advantage offered by this system is that measured values

are recorded directly at the BMD (1). The risk of errors due to extension bending is eliminated.

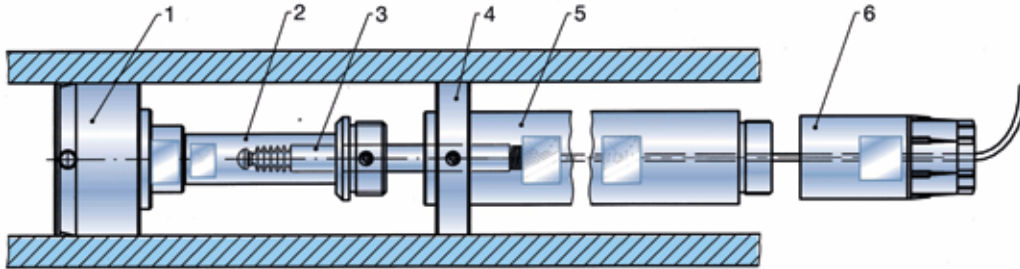

TVT15

Depth extension with 15 mm outside diameter

TVT15 depth extensions are used in combination with the EH10-61-T15 holder (31). Please note that no probe extension can be used inside the TVT, as the outside diameter of the connector is too large. A probe with a longer connection cable is required for measurement depths of more than 2 m.

L	Order Code
125	TVT15-125
250	TVT15-250
500	TVT15-500

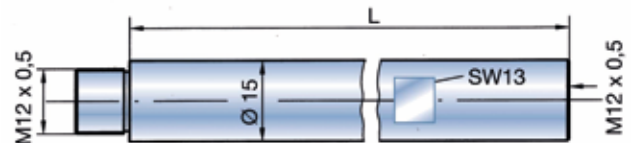

TVT28

Depth extension with 28 mm outside diameter

TVT28 depth extensions are used in combination with the EH10-61-T28 holder (31). The inside diameter of the TVT28 is large enough to permit passage of a probe extension cable with coupling (outside diameter approx. 17.2 mm). The TVT28-EHK cable clamp fixture cannot be used with this option!

L	Order Code
125	TVT28-125
250	TVT28-250
500	TVT28-500

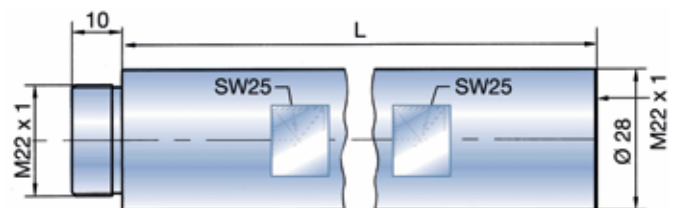

TVT-EHK

Cable clamp for TVT15 and TVT28

The cable clamp ensures safe withdrawal of the probe connection cable from the TVT.

Please note: The cable clamp cannot be used in combination with a probe extension cable!

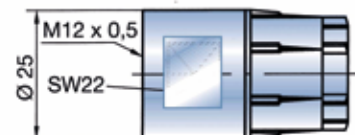

TVT15-EHK (for TVT15), Order Code TVT15-EHK

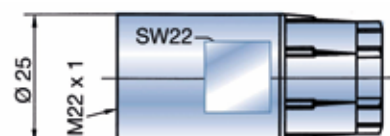

TVT28-EHK (for TVT28), Order Code TVT28-EHK

Depth stops are used to limit measuring depths. They can be clamped to the corresponding depth extension or to the holder.

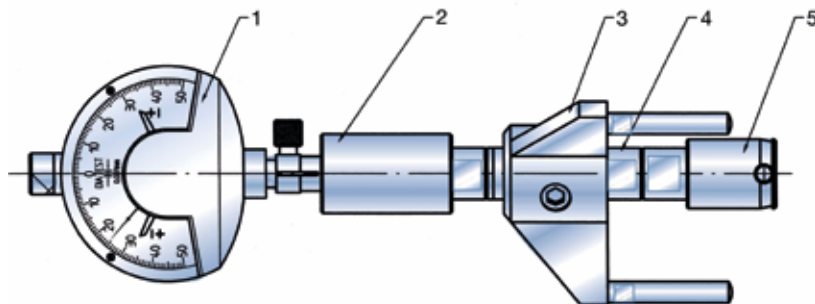

- Example: 1 = Indicator
 2 = Holder
 3 = Depth stop
 4 = Depth extension
 5 = BMD

TA8

Depth stop for Series 6

Can be attached to TV8 or holder MH6

Sizes:

- TA8 total length 83 mm
 TA8-K total length 45 mm

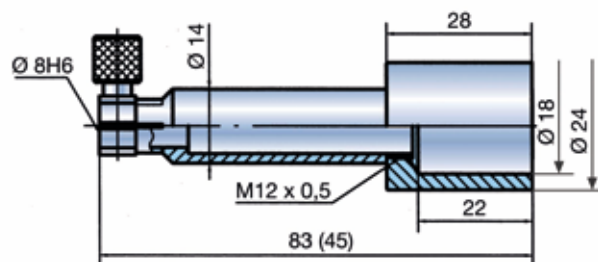

TA15

Depth stop for Series 10

Can be attached to TV15 or MH10-

Instead of the clamping fixture, the TA15 is also available with M24 x 1 threading (for screw connection to TA15-C or TA15-F, for example).

Order suffix: M24, example: TA15-45-M24

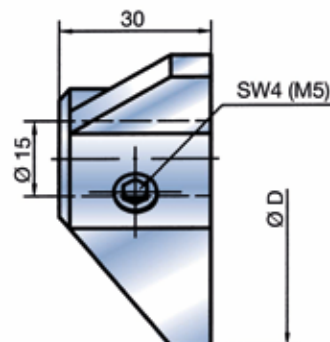

Ø D	Order Code	Ø D	Order Code
45	TA15-45	160	TA15-160
75	TA15-75	220	TA15-220
110	TA15-110	260	TA15-260

TA15-A

Depth stop for Series 10 with 3 stop pins

Can be attached to TV15 or MH10

Special version: Ø d deviating from standard
 Order suffix: SO-Ød, example: TA15-A-45-SO-Ø d=32

Instead of the clamping fixture, the TA15 is also available with M24 x 1 threading (for screw connection to TA15-C or TA15-F, for example).

Order suffix: M24
 Example: TA15-A-45-SO-Ø d = 32-M24

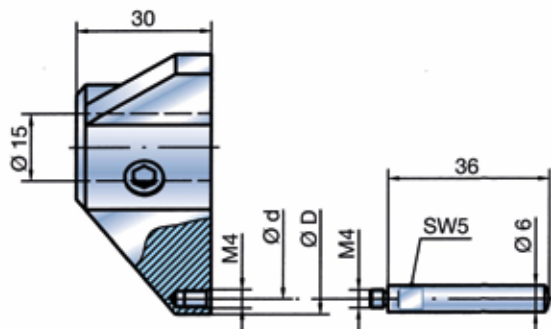

Ø D	Ø d	Order Code	Ø D	Ø d	Order Code
45	38	TA15-A-45	160	153	TA15-A-160
75	68	TA15-A-75	220	213	TA15-A-220
110	103	TA15-A-110	260	253	TA15-A-260

TA15-C

Basic depth stop body

Can be attached to TV15 or MH10.
 To be screwed onto special stop rings or TA15/TA15-A with M24 x 1 threading.
 Special stop rings can be produced on request.
 Order Code TA15-C

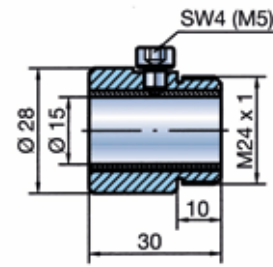

TA-KW

Depth stop designed for clamping to BMD guide cylinders

Available versions:

- TA-KW depth stop, steel, non-hardened (standard)
- TA-KH depth stop, steel with 3 carbide (HM) balls as contact points in pitch diameter TK
- TA-KG depth stop, steel, hardened
(Caution: increased risk of distortion of BMD cylinder)

TA-KW depth stops can only be produced up to 100 mm!
 Sample order: TA-KW-15.75 (= Ø d)

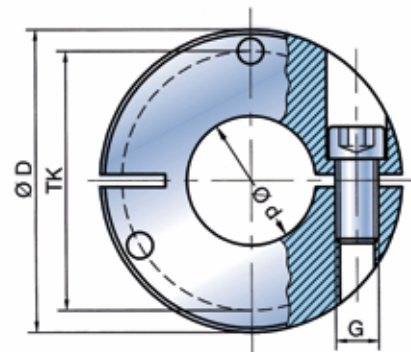

Ø d	Ø D	TK	h	G	Ø d	Ø D	TK	h	G
3-5	27	16	10	M4	35-40	65	53	12	M5
5-8	30	19	10	M4	40-45	70	58	12	M5
8-11	33	22	10	M4	45-50	75	63	12	M5
11-15	37	26	10	M4	50-60	85	73	12	M5
15-20	42	31	10	M4	60-70	95	83	12	M5
20-25	50	38	12	M5	70-80	105	93	12	M5
25-30	55	43	12	M5	80-90	115	103	12	M5
30-35	60	48	12	M5	90-100	125	113	12	M5

TA15-F

TA8-F

Spring-loaded depth stop

Can be attached to TV15 or TV8. Spring stroke is continuously adjustable from 0 to 7 mm. TA15-F can be combined with TA15-M24, TA15-A-M24 and special depth stop disks. TA8-F always has to be used in combination with special depth stop disks. Sample application: For measuring short bores on two measuring planes (taper, etc.)
 Order Code TA15-F (to be clamped on TV15)
 TA8-F (to be clamped on TV8)

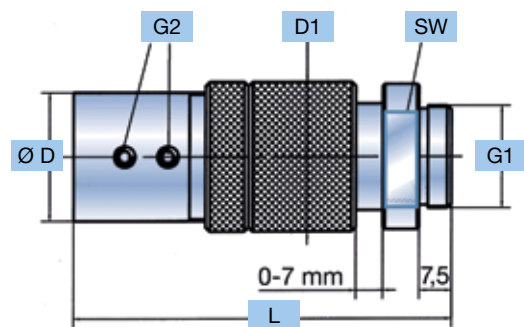

Ø D	Ø D1	G1
30	35	M24x1
20	26	M18x1

Sample application

For measuring short bores on two measuring planes (taper, etc.).

The TA15-F (1) with special depth stop ring (2) is attached to a depth extension (3).

The workpiece (4) is pulled over the BMD to the stop point.

After first measurement, the workpiece is pressed to the end of spring stroke, and a second measurement is taken.

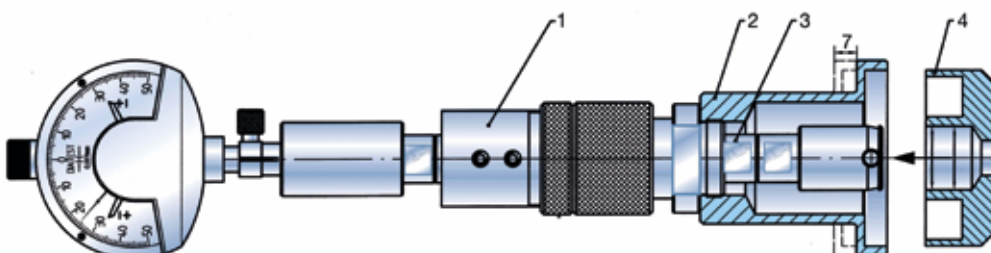

This unit can also be configured as a measuring station (42). Special depth stop rings available on request.



These fixtures are used for stationary measurements of smaller workpieces. One or more BMD unit can be installed.

Applications: direct measurement at production machines, honing machines, grinding machines, etc. Can be combined with standard components of BMD Series 6 and 10. Series 4 BMD must be adapted accordingly. A wide range of adjustment options ensures optimum handling. Special models with longer midsections (for large BMD plug gauges) or longer side components are available on request. Clamping brackets used to mount the KM (e.g. on a workbench) are listed on 42 (KM-KB). Not included in the delivery package.

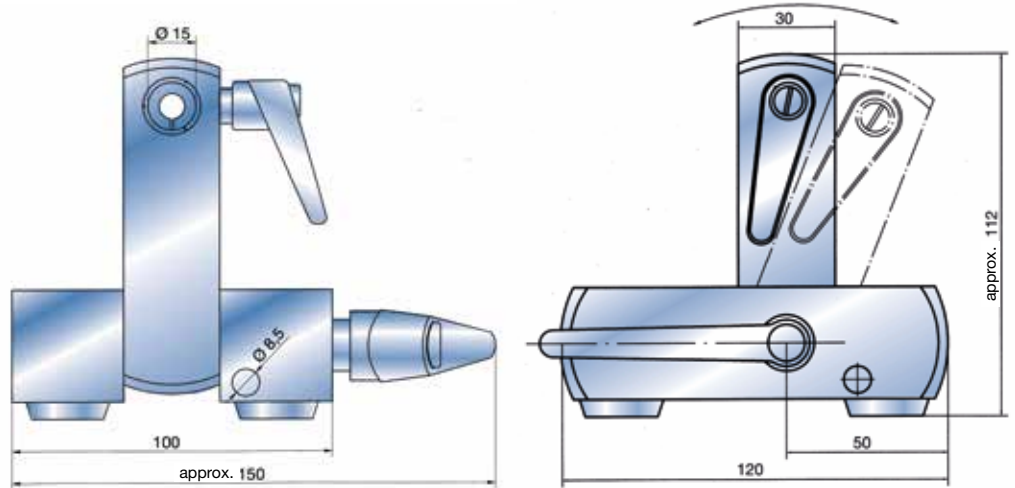

KM-MH

Indicator holder

Can be clamped directly into the KM. Without plastic grip. Order Code KM-MH

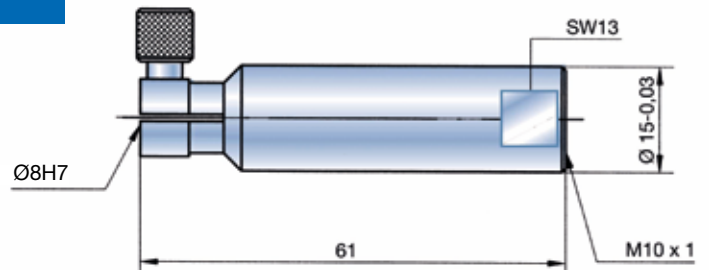

KM-GK

Slotted clamping sleeve

For clamping TV8 depth extensions into the KM. Order Code KM-GK

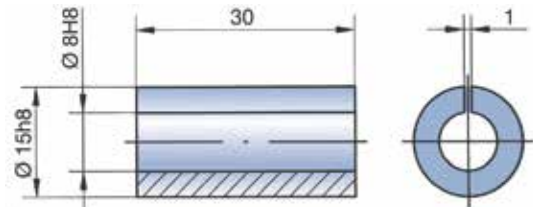

KM-KB

Clamping bracket

For mounting the small measurement fixture (e.g. on a workbench). The $\varnothing 8$ bolt is inserted into the $\varnothing 8.5$ bore in the KM. Not included with the KM. Order Code KM-KB

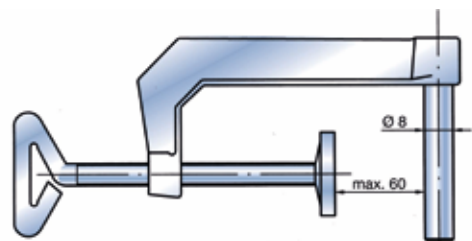

KM-VK

Adjustable clamping lever

For TA15 depth stops. Facilitates rapid depth stop adjustment. Order Code KM-VK

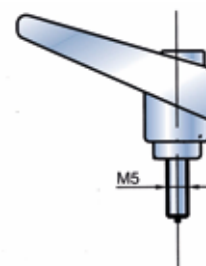

Sample applications

An EH can also be used instead of a KM-MH for an inductive probe (E 29). In this case, an additional TV15 is required and clamped into the KM.

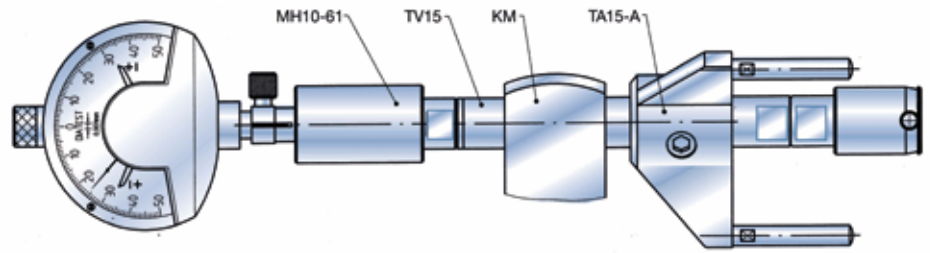
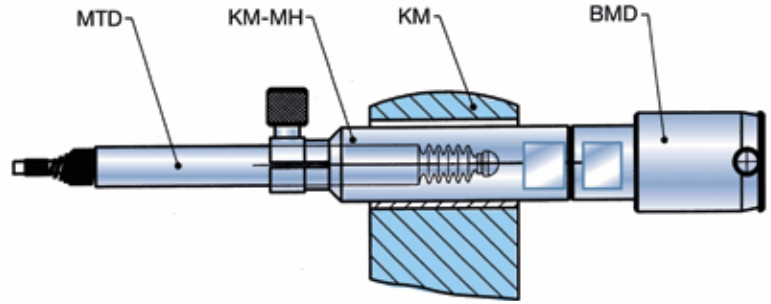

The KM-GK slotted clamping sleeve is always used as an adapter when clamping a TV8.

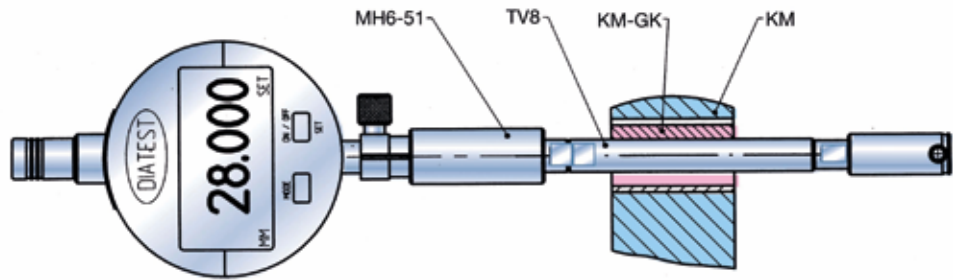

Several KM fixtures can be combined.

Bestell-Nr.	X
KM1	0
KM2	80
KM3	80-80
KM4	80-80-80
KM5	80-80-80-80
KM6	80-80-80-80-80

Fixtures with different dimensions X (min. 30 mm) or more measurement points than the KM6 as well as individual components required to upgrade existing small measurement fixtures are available on request.

The W6 right-angle attachment and matching holder are required for use with BMD series 6 and a TV8.

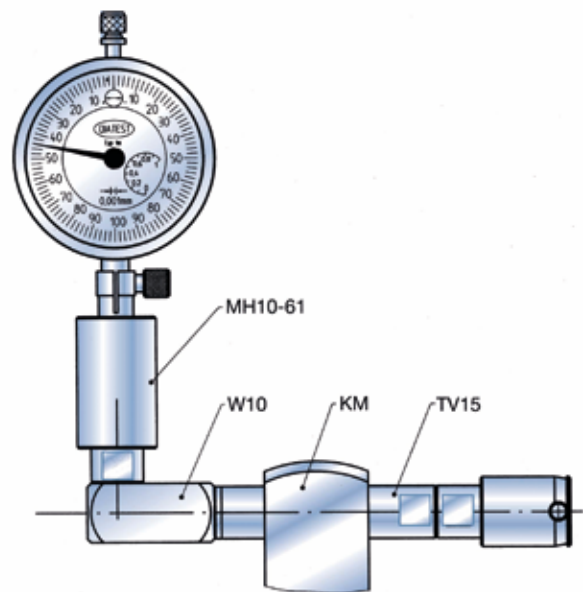
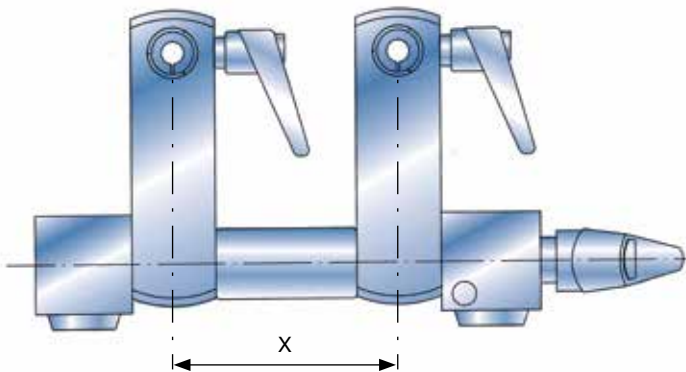

Small measuring fixtures for multiplane plugs

The holder for EH-M40 x 1.5 multiplane plugs can be clamped directly into the KM-ME.

The EH-M35 x 1.5 holder can only be clamped with the aid of a KM-ME35-40 clamping sleeve.

Special versions with longer mid-sections (for large BMD diameters) or longer side elements are available on request.

Clamping brackets for use in mounting the KM (e.g. to a workbench), see 42. Not included in the delivery package.

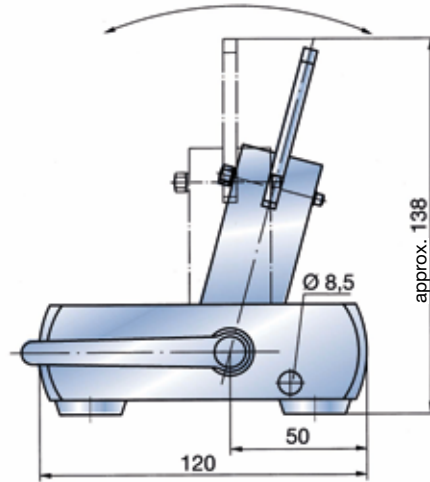
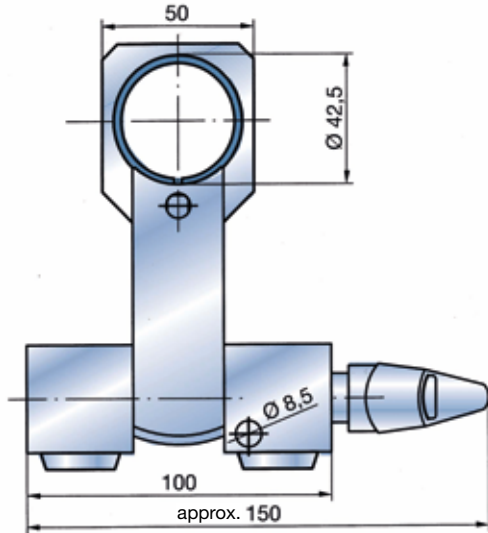

Several KM-ME fixtures can be combined.

Order Code	X
KM-ME1	0
KM-ME2	80
KM-ME3	80-80
KM-ME4	80-80-80
KM-ME5	80-80-80-80
KM-ME6	80-80-80-80-80

Fixtures with different dimensions X (min. 30 mm) or more measurement points than the KM-ME6 as well as individual components required to upgrade existing small measurement fixtures are available on request.

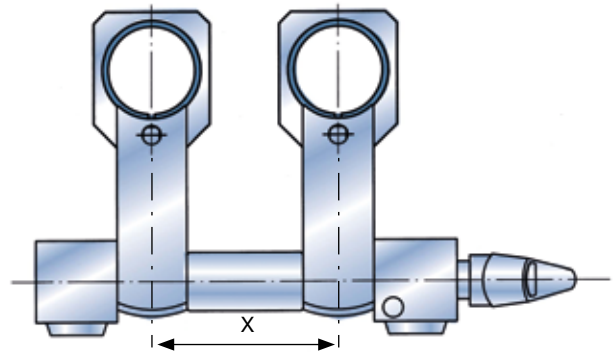

KM-ME35-40

Slotted clamping sleeve

Required for clamping the EH-M35 x 1.5 holder into the KM-ME.

Order Code KM-ME35-40

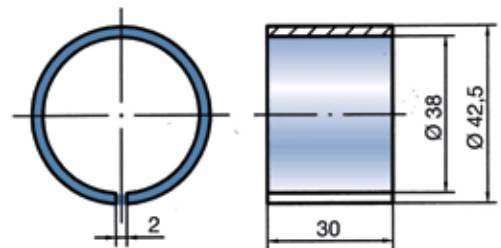

Sample application

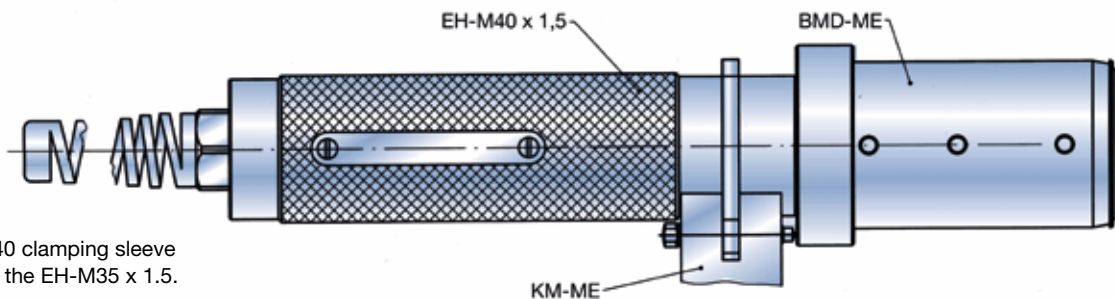

A KM-ME35-40 clamping sleeve is required for the EH-M35 x 1.5.

Diatest delivers measuring fixtures on customers request based on our product range.

Examples

Fixture 1

Measuring table with space for setting master and BMD for internal and external measurement



Fixture 2

Measuring table with dial indicator holder for flatness inspection

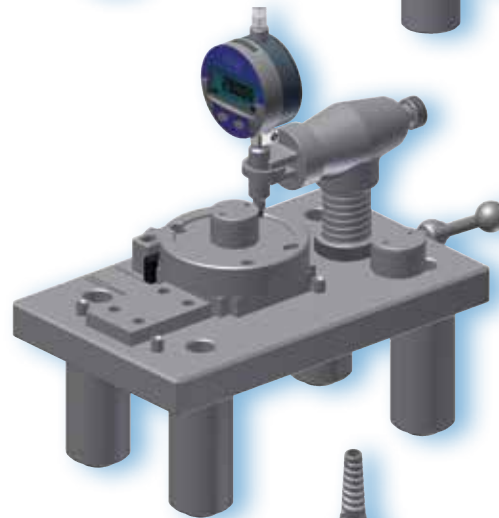

Fixture 3

Measuring table with extension and BMD for internal and external measurement

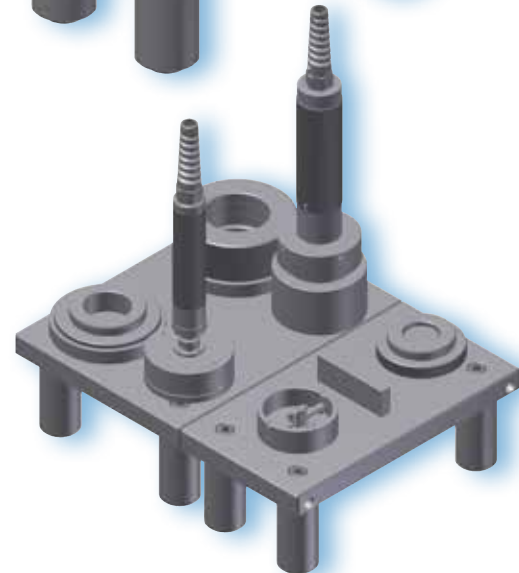

Fixture 4

Measuring table for checking of parallel distances on 2, 4 or 6 points

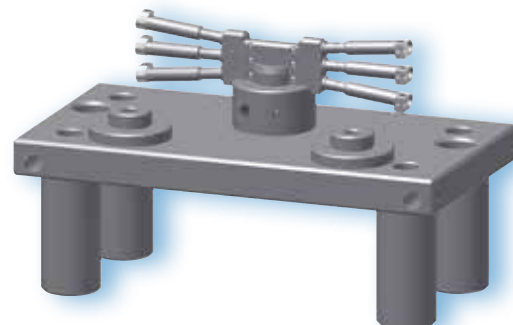

SH-BMD Floating holders

Floating holders (2) are used in combination with BMD type PK with pilot taper (3) for measurements in fixtures. The purpose of the floating holder is to compensate for positioning errors from BMD to bore and to bridge minor angular errors from BMD to bore axis.

Floating holders are mounted in clamping sleeves with diameters of 20, 30 and 50 mm. They should not be clamped too tightly in order to ensure the function of the float holder.

Floating holders SH-BMD20 and SH-BMD30 do not have anti-twist protection. When using an inductive probe, a probe spacer ring is required (MUZ10). It may be necessary to remove the protective bellows in the inductive probe.

Option AT0 is recommended for applications involving frequent BMD changes (see 8), especially for indicator units with inductive probes (1).

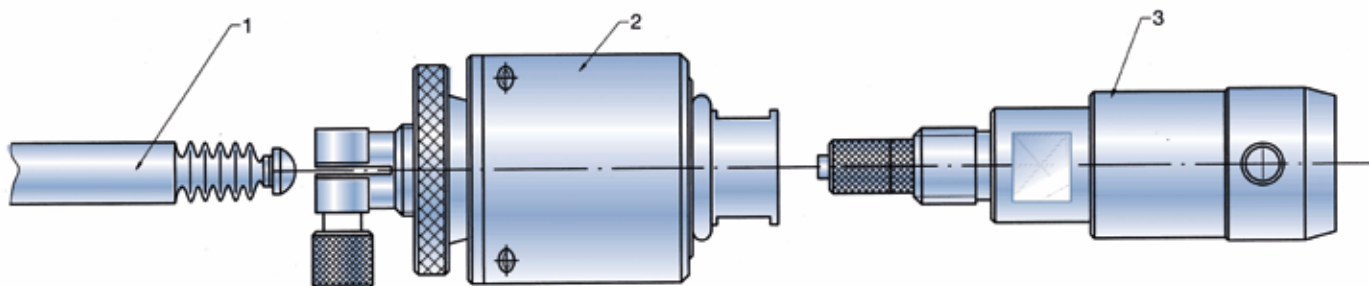

SH-BMD20

Floating holder with 20 mm outside diameter

Order Code SH-BMD20-6

Technical data

Adjusting nut (A)	Float range	Axial tilt angle<
0 revolutions	± 0 mm	0°
1 revolutions	± 0.13 mm	2° 40'
2 revolutions	± 0.26 mm	3°
3 revolutions	± 0.39 mm	3° 20'
4 revolutions	± 0.5 mm	3° 35'

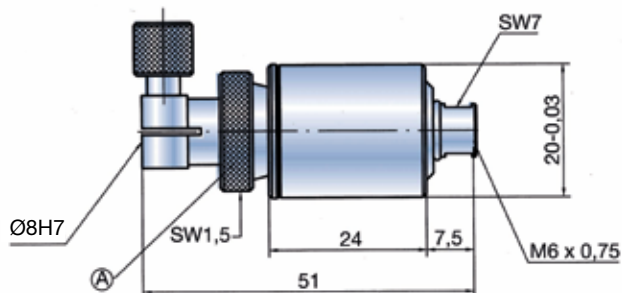

SH-BMD30

Floating holder with 30 mm outside diameter

Order Code SH-BMD30-6 (connection thread M6 x 0,75)
SH-BMD30-10 (connection thread M10 x 1)

Technical data

Adjusting nut (A)	Float range	Axial tilt angle<
0 revolutions	± 0 mm	0°
1 revolutions	± 0.125 mm	0° 30'
2 revolutions	± 0.25 mm	0° 50'
3 revolutions	± 0.375 mm	1°
4 revolutions	± 0.5 mm	1° 5'
5 revolutions	± 0.625 mm	1° 10'
6 revolutions	± 0.75 mm	1° 10'

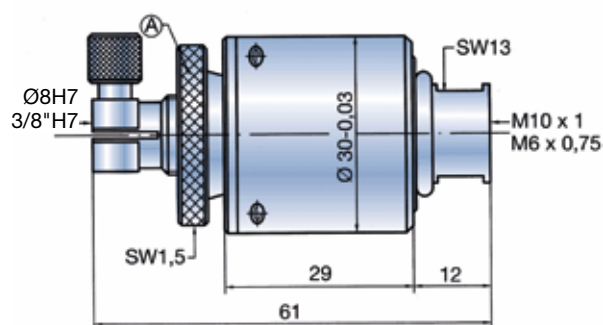

Setting the float range for SH-BMD20+30

Set the adjusting nut (A) to float range 0, but do not tighten, as otherwise the holder will be pulled backwards along with the BMD and will no longer float in parallel!

Then set the desired float range and tighten the adjusting nut with an Allan wrench. When using small-diameter BMD, it is especially important to ensure that the float range is not set too high. An excessively large float range can cause collision of the front face of the BMD.

SH-BMD50

Floating holder with anti-impact protection

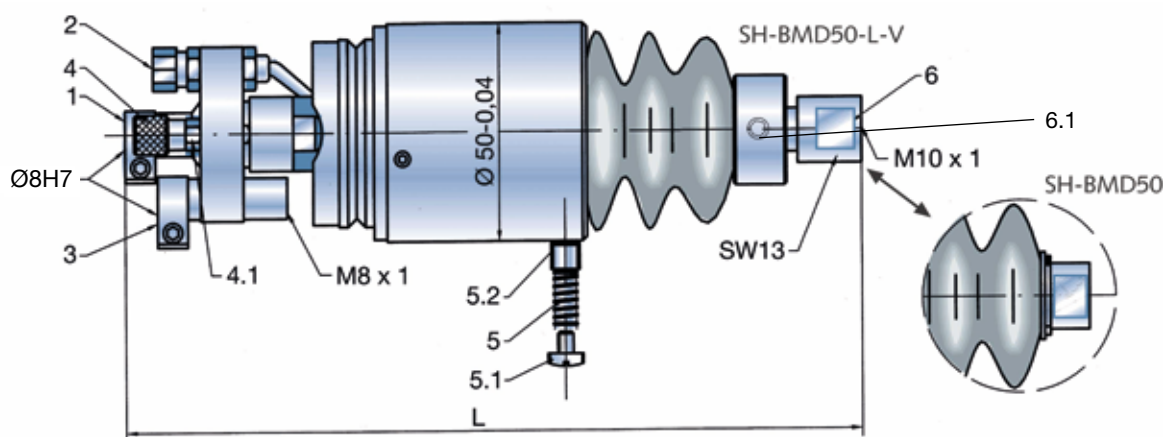

Floating holders with anti-impact protection are generally used in fully automatic measuring systems. The floating holder is secured against twisting.

Models

SH-BMD50	Without air supply or fine adjustment L = 150
SH-BMD50-V	Without air supply, with fine adjustment L = 165±1,5
SH-BMD50-L-V	With air supply and fine adjustment L = 165±1,5

Applications

BMD up to nom. diameter of 150 mm with horizontal installation, BMD up to nom. diameter of 250 mm with vertical installation, BMD with Option L (with air outlet at the gauging contacts)

Fine adjustment (Type V)

If the BMD is changed frequently, the probe can be calibrated to the electronic zero point on the fine adjustment unit without shifting the position of the probe itself.

Anti-impact protection

with 22 mm recoil stroke

Sample applications:

- Bore missing, workpiece incorrectly positioned, etc. The SH-BMD with proximity switch stops the machine if recoil is too great.
- BMD moves to the bottom or step of a blind or stepped bore. The bore depth is measured additionally via the recoil stroke of the SH-BMD50 and an electronic probe.
- BMD-SO-KO (see 18) is inserted into the bore to the depth stop point.

Technical description

- 1 Collet bore Ø 8H6 with tangential clamp for mounting the probe.
- 2 Compressed air hose (c. 3-4 bar) only for version "L"
- 3 Collet bore Ø 8H6 for proximity switch with M8 x 1 threading in the front section
- 4 Set screw for float range.
1 revolution = ±0.25 mm float range
- 4.1 SW7 lock nut to secure set screw.
For float range = 0: Tighten nut against the set screw, tighten adjusting screw completely.
- 5 Weight balance spring with variable spring pressure of 4-30 N
- 5.1 Set screw for weight balancing
- 5.2 Spring sleeve
- 6 Type V: The fine adjustment fixture can be adjusted by ±1.5 mm by loosening the clamping screw SW3 (6.1). It is no longer necessary to move the probe for change of BMD.

Setting the float range

Tighten nut 4.1 slightly against the head of set screw 4. Tighten screw 4 to the stop point (= float range 0). Turn back screw 4 (1 revolution = ±0.25 mm float range) until the desired float range is set. Tighten screw 4 against nut 4.1 to secure the screw against turning. The maximum float range is ±0.75 mm.

Weight compensation

In horizontal applications, the BMD is balanced in the center position by adjusting set screw 5.1 or replacing spring 5. This prevents excessive wear on the pilot taper when the plug is inserted into the bore. The delivery package includes 2 springs with different strengths. Spring 5 must be removed in vertical configurations.



SH-BMD50-10

Protective sleeve for SH-BMD50

This sleeve protects the fitted electronic probe and proximity switch. three pinch screwings (for electronic probe, proximity switch and air hose) ensure all cables have strain relief and provide splash-proof protection.

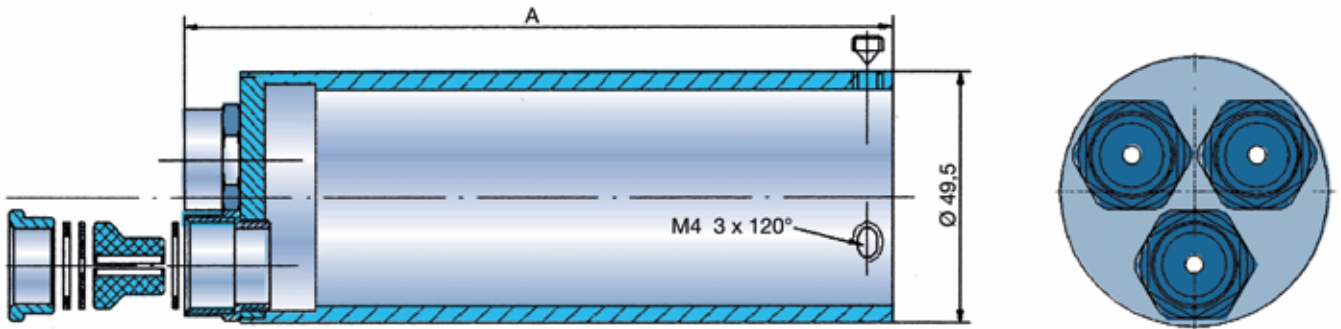

Sizes

Length A	Order Code
152 mm	SH-BMD50-10
190 mm	SH-BMD50-10-190

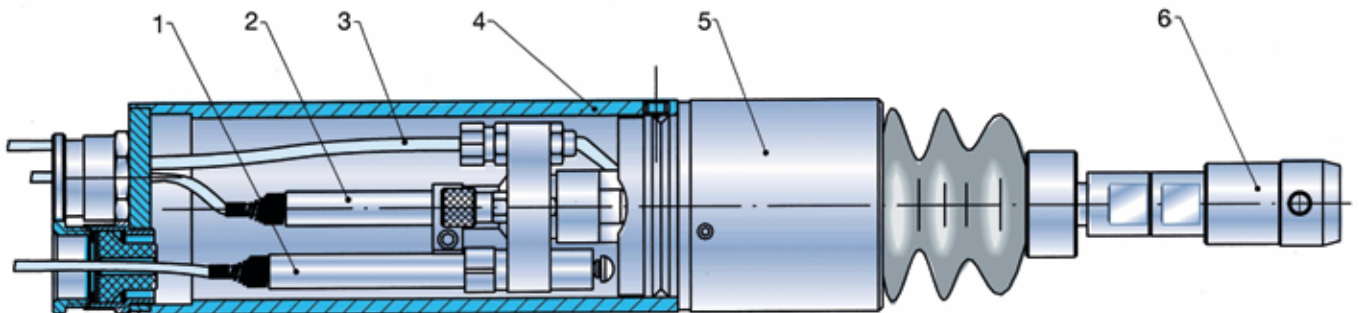

Example

- 1 Proximity switch or probe
- 2 Electr. probe
- 3 Air hose
- 4 Protective sleeve
- 5 Floating holder
- 6 BMD-PK



SH-BMD-ME

Floating holder for multiplane plug gauges

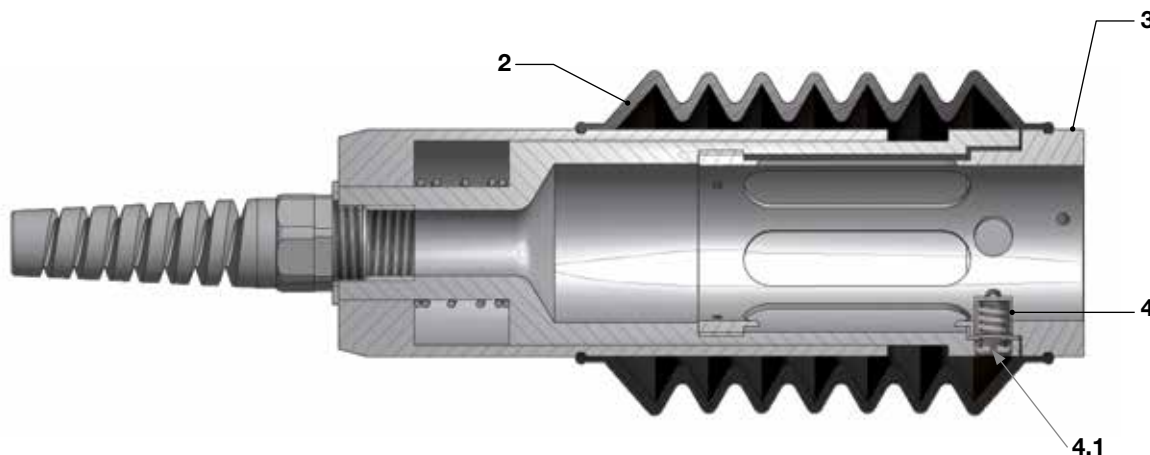

The floating holder for multiplane plug gauges with anti-impact protection is designed exclusively for use with type ME-BMD (22).

Please note:

Connection type 5, size 2 (see 22) is required for installation of a multiplane BMD.

Weight compensation

For horizontal applications, the BMD is balanced in an approximate central position by adjusting the two set screws 4.1 or by replacing the two springs 4. The 2 set screws are positioned at an angle of 96° and must be aligned during installation in such a way that they point downward and are offset by c. 48° to the vertical axis.

Technical description

- 1 M8 x 1 threaded bore for proximity switch (anti-impact protection). Spring stroke approx. 20 mm
- 2 Protective bellows to protect against splashing

- 3 Spring cage allows free floating. Float range approx. ±1 mm; non-adjustable.
- 4 Weight compensation spring for horizontal applications. Total of two spring sets at an angle of 96°. The springs must be positioned during installation in the machine or fixture in such a way that weight compensation can be achieved. The springs must be removed for vertical installation of the SH-BMD-ME.
- 5 Anti-twist protection. The floating holder is protected against twisting.
- 6 3 mounting screws for multiplane BMD (3 x 120°). A type 5 connection on the BMD is required for plug gauge installation.
- 7 Probe with Ø 8h6 extension diameter (and air hose, if applicable). The cable and hose are drawn out of the floating holder through the anti-bend protector.
- 8 Type 5, size 2 connection (on BMD)
- 9 Multiplane BMD
- 10 Pilot taper

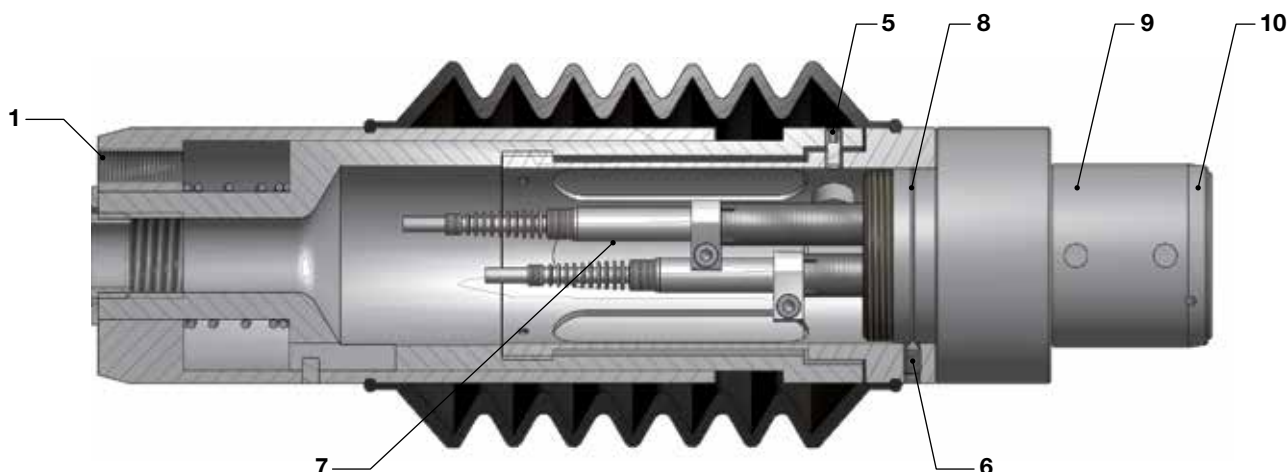

E Spare parts

Some BMD components are replaceable. However, it is essential to ensure that the correct parts are used. Use of the wrong parts will result in incorrect measurements.

Part codes:

HM-T Carbide pressure needle
 F F Spring (not for Series 4)
 FH Spring sleeve

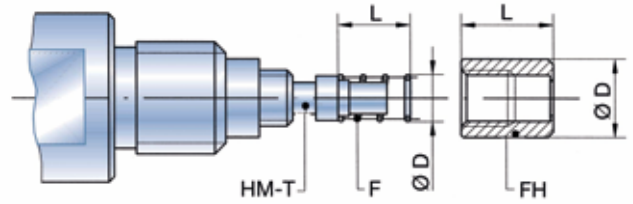

HM-T

Carbide pressure needles

Pressure needles can be replaced separately. It is important to ensure that the correct pressure needles are used. Pressure needles are marked with notches.

no notch 2-point BMD, BMD-FB6
 2 notches BMD-FB10
 3 notches 3-point BMD
 more than 3 notches Special-purpose pressure needle

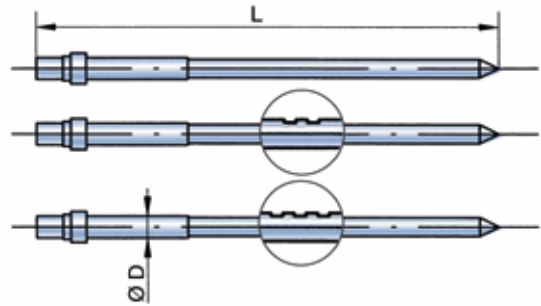

Description HM-T	Series 4 (M3,5 x 0,35)				Series 6 (M6 x 0,75)				Series 10 (M10 x 1)			
	Ø D	L	Notches	Order Code	Ø D	L	Notches	Order Code	Ø D	L	Notches	Order Code
2-point	1.5	42.8	0	HM-T4	1.5	42.8	0	HM-T6	2.7	59.5	0	HM-T10
FB					1.5	42.8	0	HM-T6	2.7	59.5	2	HM-T10-FB
3-point					1.5	42.5	3	HM-T6-3P	2.7	58.5	3	HM-T10-3P
spring					2.5	4		F6	3.7	10		F10
spring sleeve	2.8	6		FH4	4.5	5		FH6	7	8.5		FH10

ZU Accessories: Setting rings according to DIN 2250-C and DIATEST company standard

Setting rings are used to calibrate the measuring device. Setting rings to DIN 2250-C standard are suited best for this

purpose. They are available in all intermediate sizes from Ø 1 mm to 315 mm.

Settings rings to DIATEST company standard may also be used. However, these rings are only available in fixed diameters (from Ø 3,0 to 40,0 mm).

Setting rings DIN 2250-C, tolerance table

Version mm	Nominal-Sizes		Dimensions		
	d ₁	b ₁	d ₂	d ₃	
> 1 - 2,5	4	22			
> 2,5 - 3	5	22			
> 3 - 5	5	22			
> 5 - 6	8	32			
> 6 - 10	8	32			
> 10 - 15	10	38			
> 15 - 18	12	45			
> 18 - 20	12	45			
> 20 - 25	14	53			
> 25 - 30	16	63			
> 30 - 32	16	63			
> 32 - 40	18	71			
> 40 - 50	20	85			
> 50 - 60	20	100			
> 60 - 70	24	112			
> 70 - 80	24	125			
> 80 - 90	24	140			
> 90 - 100	24	160			

Setting rings DIN 2250-C, tolerance table

Version mm	Nominal-Sizes		Dimensions			
	d ₁	b ₁	b ₂	d ₂	d ₃	
> 100 - 110	28	14	170	132		
> 110 - 120	28	16	180	140		
> 120 - 130	28	16	190	150		
> 130 - 140	28	18	200	160		
> 140 - 150	28	18	212	170		
> 150 - 160	28	20	224	180		
> 160 - 170	32	20	236	190		
> 170 - 180	32	20	250	200		
> 180 - 190	32	22	265	212		
> 190 - 200	32	22	280	224		
> 200 - 212	32	22	300	236		
> 212 - 224	32	25	315	250		
> 224 - 236	36	25	335	265		
> 236 - 250	36	28	355	280		
> 250 - 265	36	28	375	300		
> 265 - 280	36	28	400	315		
> 280 - 300	36	32	425	335		
> 300 - 315	36	32	450	355		

Also available in inch sizes

Setting rings - DIA TEST company standard

Nom. diameter Ø N mm	Outside Ø A mm	Height H mm	Nom. diameter Ø N mm	Outside Ø A mm	Height H mm
R - 2.000	20.0	4.5	R - 16.000	36.0	7.5
R - 2.250	20.0	4.5	R - 16.500	36.0	7.5
R - 2.500	20.0	4.5	R - 17.000	36.0	7.5
R - 2.750	20.0	4.5	R - 18.000	36.0	7.5
R - 3.000	20.0	4.5	R - 19.000	36.0	7.5
R - 3.250	20.0	4.5	R - 20.000	36.0	7.5
R - 3.500	20.0	4.5	R - 21.000	45.0	10.0
R - 3.750	20.0	4.5	R - 21.500	45.0	10.0
R - 4.000	20.0	4.5	R - 22.000	45.0	10.0
R - 4.500	20.0	4.5	R - 23.000	45.0	10.0
R - 5.000	20.0	4.5	R - 24.000	45.0	10.0
R - 5.500	20.0	4.5	R - 25.000	45.0	10.0
R - 5.750	20.0	4.5	R - 25.500	45.0	10.0
R - 6.000	20.0	4.5	R - 26.500	45.0	10.0
R - 6.500	20.0	4.5	R - 27.000	45.0	10.0
R - 7.000	20.0	4.5	R - 28.000	45.0	10.0
R - 7.500	20.0	4.5	R - 29.000	45.0	10.0
R - 7.750	20.0	4.5	R - 30.000	45.0	10.0
R - 8.000	20.0	4.5	R - 31.000	60.0	12.0
R - 8.500	20.0	4.5	R - 32.000	60.0	12.0
R - 9.000	20.0	4.5	R - 33.000	60.0	12.0
R - 9.500	20.0	4.5	R - 34.000	60.0	12.0
R - 10.000	36.0	7.5	R - 35.000	60.0	12.0
R - 11.000	36.0	7.5	R - 36.000	60.0	12.0
R - 11.500	36.0	7.5	R - 37.000	60.0	12.0
R - 12.000	36.0	7.5	R - 38.000	60.0	12.0
R - 13.000	36.0	7.5	R - 39.000	60.0	12.0
R - 14.000	36.0	7.5	R - 40.000	60.0	12.0
R - 15.000	36.0	7.5			

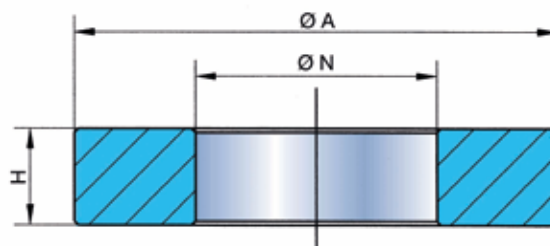

Accuracy of DIA TEST setting rings (company standard)

Max. deviation from nom. diameter:	0.0009 mm
Max. concentricity error:	0.0003 mm
Max. rough dept:	0.00002 mm
Hardness:	62-64 HRC

Order Code = R-nom. diameter
Sample order: R-25.500

Also available:

- DIA TEST-Setting rings with Ø 10.5 / 11.5 / 12.5 ... to 29.5
- Also available in fixed inch sizes

	Page		Page		Page
A	- Adapter	34-35	MR	- Gauging radius	6
AD	- Cover	7	MRU	- ruby contact points	7
AH	- Holder for Analogic indicator	33	MZ	- Reduced cylinder diameter tolerance	8
ATO	- Toleranced connecting length	8	M24	- Depth stop with M24 threading	40, 41
BL	- Holder with marking strip	26	NHM	- Pressure needle for BMD-PA-6	21
BLE	- Replacement marking strip	26	NFB	- Pressure needle f. BMD-PA-6	21
BM	- Inspection plug	8	NT-HM	- Pressure needle f. BMD-PA-4	21
BMD	- Plug gauge	10-23	NT-FB	- Pressure needle for BMD-PA-4-FB	21
D	- Basic BMD type for through bores	11	OCR	- BMD with steel cylinder (not chrome coated)	4
D	- Order suffix for rotary adapter/holder	32, 38	OD	- BMD for outside diameter	20
EH, EHT	- Holder for electronic probes	29, 31	OR	- BMD without pilot taper	15
F	- Order suffix for depth extension with spring	30, 50	PA	- BMD gauge for parallel wall gauging	21
FB	- Basic type for blind bores	12	PG	- BMD without inherent measurement pressure	8
GK	- Slotted clamping sleeve	42	PK	- BMD with pilot taper	9, 14
HM	- Carbide	42-44	R	- Gauging radius (dimension)	6
HM-T	- Carbide pressure needle	13, 30, 47	- Setting ring	50	
KB	- Clamping bracket	6	S	- Basic type standard BMD	10
KM	- Small measurement fixtures	50	S-FB	- BMD, Type S with shortened L1	15
L	- BMD or accessories with air supply	42-44	SH-BMD	- Floating holder for BMD PK	46-49
MB-B	- Measurement range limitation	6	SO	- Special-purpose design	15-20
MB-SO	- Measurement range extension	5	SO-B	- Special marking	4
MCR	- Hard chrome contact points	6	SO-DZL	- BMD with extended L1	17
MDI	- Diamond contact points	7	SO-FB-SO	- BMD for stepped bores	18
ME	- Multiplane plug gauges	22-23	SO-GL	- BMD for longitudinal groove measurement	18
MH	- Indicator holders	24-28			
MHM	- carbide contact points	6			
MKE	- ceramic contact points	6			
MKK	- Plastic gauging contacts	7			
			SO-KO	- BMD for tapered inside diameters	18
			SO-KW	- BMD for crankshaft bearing width	19
			SO-PA	- BMD for parallel wall measurement	19
			SO-SZ	- BMD with special cylinder	19
			SO-ZL	- BMD with extended L1 and/or L2	17
			SO-TA	- BMD with built-in depth stop	16
			SO-W	- Right-angle attachment and BMD plug gauge; short form	36
			SO-2Z	- BMD with 2 guide cylinders	18
			TA	- Depth stops	40, 41
			T-BMD	- BMD for small diameters	17
			TV	- Depth extension with transfer pin	37, 38
			TVT	- Depth extension without pressure pin	37, 38
			UM	- BMD with reduced entry diameter	15
			V	- Holder or floating holder with fine adjustment	102, 30, 47
			VK	- Adjustable clamping lever	42
			W	- Right-angle attachment	36
			Z	- Order Code for 3/8" special bore	24-33
			ZHML	- BMD with carbide bars	14
			ZKUL	- BMD with plastic bars	17
			2R	- BMD with 2 guide grooves	16
			SO-2Z	- BMD with 2 cylinders	18
			3P	- BMD in 3-point configuration	9, 16



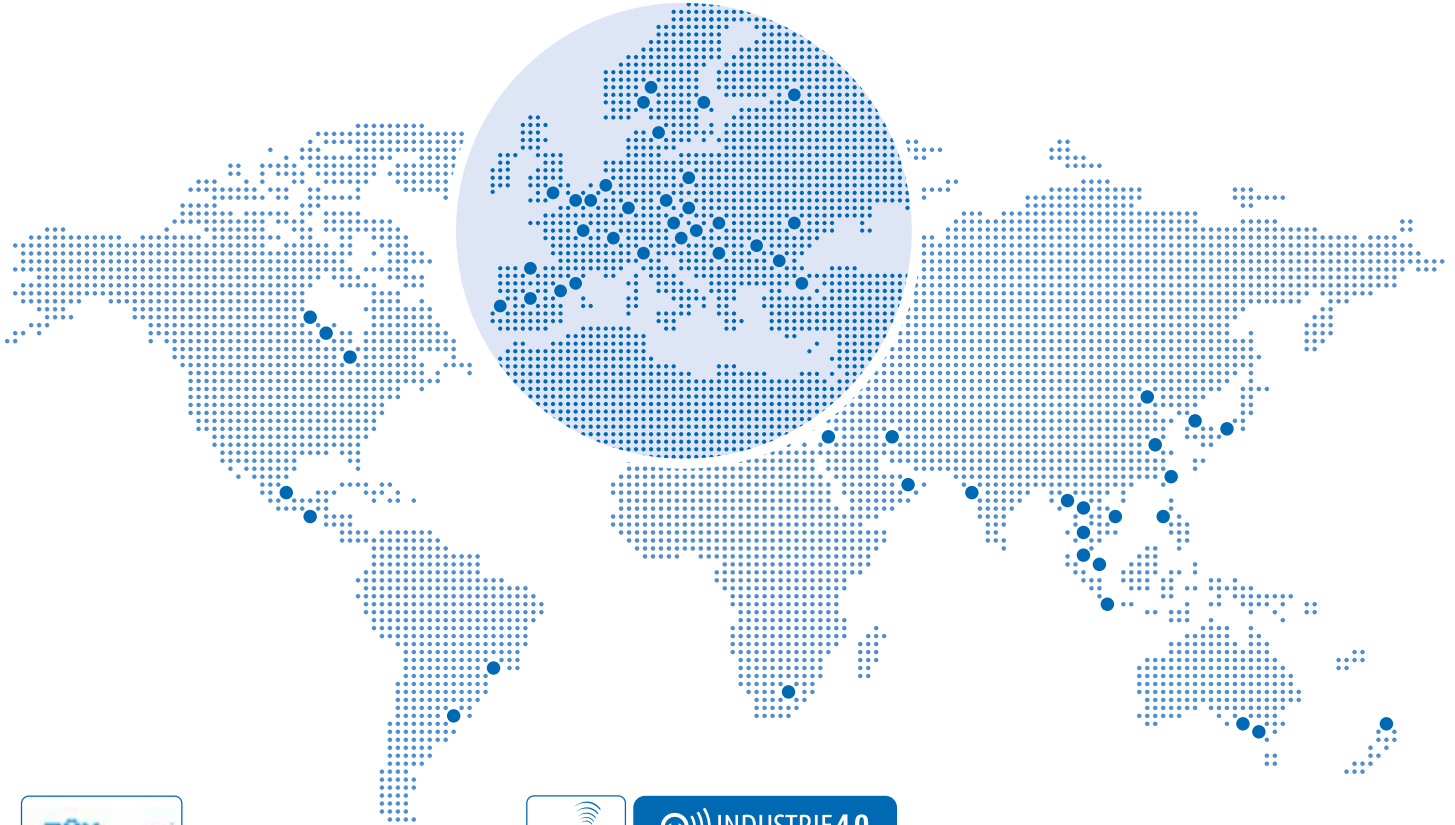

INDUSTRIE 4.0

Networking of Data

2020/05/E

Brazil

DIATEST do BRASIL

Produtos de Medição LTDA
R. Ulisses Cruz, nº 1052 -
3º.andar – CJ.06 – Tatuapé
ZIP: 03077-000 – São Paulo –
SP – Brazil
 +55 1120918811
 info@diatest.com.br
www.diatest.com.br

Germany

DIATEST Hermann Költgen GmbH

Schottener Weg 6
D-64289 Darmstadt
Germany
 +49 61519790
 +49 6151979111
 info@diatest.com
www.diatest.com

France

DIATEST COME Metrologie

145, Avenue du Stade
42170 St. Just St. Rambert
France
 +33 477550139
 info@diatest-come.fr
www.diatest-come.fr

Japan

DIATEST JAPAN Ltd.

15-29, 1-Chome Hitotsuya
580-0003 Matsubara City,
Osaka
Japan
 +81 723306661
 +81 723338223
 d-info@diatest-j.co.jp
www.diatest-j.co.jp

Sweden

DIATEST Sverige

AB Hans Ehlers
Ranhammarsvägen 24
168 67 Bromma
Sweden
 +46 856470188
 +46 8362279
 info@diatest.se
www.diatest.se

USA

DIATEST USA

1188 Heather Drive
Lake Zurich, IL 60047
 +1 1800-DIATEST
 847-550-4024
 847-847-1947
 info@diatestusa.com
www.diatest.us

United Kingdom

DIATEST (U.K.) Ltd.

18, Avondale Avenue,
Hinchley Wood, Surrey,
KT10 ODA
England
 +44 2083981100
 +44 2083989887
 sales@diatest.co.uk
www.diatest.co.uk

People's Republic of China

DIATEST Measuring Instruments (Beijing) Co., Ltd.

Room 602, Ocean Business Center
No. 61 Balizhuang Xili,
Chaoyang District
100025 Beijing
 +86 1085865481
 +86 13701161985
 +86 1085865483
 china@diatest.com.cn
www.diatest.cn